

Level Plus®

Magnetostrictive Liquid-Level Sensors
with Temposonics® Technology

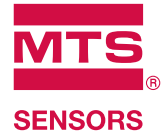

M-Series Model MC420 Transmitter with Analog Output

Document Part Number
550752 Revision I

Data Sheet

FEATURES

- 4 to 20 mA Output with HART®
- Single Channel Output
- Level Measurements
 - Product
 - Interface
- No Scheduled Maintenance or Recalibration
- High Accuracy and Repeatability
- Intrinsically Safe (I.S.)

APPLICATIONS

- General Process
- Industrial Chemicals
- Solvents
- Detergents and Soaps
- Lubricating Oils

MARKETS

- Petrochemical
- Chemical
- Water and Wastewater
- Mining

Product overview

The Level Plus® Model MC420 level transmitter satisfies the demand for an economical analog communication interface offering for hazardous area applications. The Model MC420 provides a single-channel analog 4 to 20 mA output for either a product level or an interface level measurement depending on the application and the selected float. The Model MC420 transmitter is approved by FM, CSA, NEPSI, and ATEX for use in Intrinsically Safe applications. Appropriate barriers are required when installing the Model MC420 transmitter in hazardous areas.

In addition to the single-channel 4 to 20 mA loop, the Model MC420 transmitter provides the HART® field communications protocol for setup and calibration. Calibration can also be accomplished using integrated reed switches and a supplied magnet without the need for expensive electronics. Once the transmitter is installed and calibrated there is no requirement for scheduled maintenance or recalibration.

Set it and forget it!

The Model MC420 transmitter is available in set lengths from 457 mm (18 in.) to 5486 mm (216 in.) and can be installed in applications with process temperatures between -40 °C (-40 °F) to 125 °C (257 °F). The electronics are permanently sealed in a NEMA Type 4X rated housing made of 316L stainless steel that provides protection against corrosion and resistance to harsh process conditions.



**Model MC420 Transmitter
with NEMA Type 4X Enclosure**

All specifications are subject to change. Contact MTS for specifications and engineering drawings that are critical to your application. Drawings contained in this document are for reference only. Go to <http://www.mtssensors.com> for the latest support documentation and related media.

Product specifications

Parameters	Specifications	Parameters	Specifications
LEVEL OUTPUT		ENVIRONMENTAL	
Measured variable:	Product level and interface level	Enclosure rating:	NEMA Type 4X
Output signal and Protocol:	4 to 20 mA with HART®	Humidity:	0 to 100% relative humidity, noncondensing
Order length:	Rigid pipe: 457 mm (18 in.) to 5486 mm (216 in.) § § Order length equals the measurement range plus the inactive zone.	Operating temperatures:	Electronics: -34 °C (-30 °F) to 71 °C (160 °F) Sensing element: -40 °C (-40 °F) to 125 °C (257 °F) ◇ ◇ Contact factory for specific temperature ranges.
Non-linearity:	0.02% F.S. or 0.794 mm (1/32 in.)* * Whichever is greater	Vessel pressure:	Dependent on float pressure, contact factory for more information
Repeatability:	0.01% F.S. or 0.381 mm (0.015 in.)* (any direction) * Whichever is greater	Materials:	Wetted parts: 316L stainless steel Non-wetted parts: 316L stainless steel
ELECTRONICS		FIELD INSTALLATION	
Input voltage:	10.5 to 36 Vdc maximum 28 Vdc maximum for I.S. approved	Housing dimensions:	NEMA Type 4X: 81 mm (3.2 in.) by 123 mm (4.85 in.) O.D.
Fail safe:	High (21.4 mA), Low (3.8 mA)	Mounting:	Rigid pipe: ¾ in. Adjustable MNPT fitting
Reverse polarity protection:	Series diode	Wiring:	Integral cable: 4.5 m (15 ft.) 2-wire integral cable, shielded
Lightning/Transient protection:	Stage 1: Line-to-ground surge suppression; IEC 61000-4-5 Stage 2: Line-to-line and line-to-ground transient suppressors; IEC 61000-4-4	Electrical Connections:	NEMA Type 4X: ½ in. FNPT conduit opening
CALIBRATION			
Zero adjust range:	Anywhere within the active length		
Span adjust range:	Full scale to 152 mm (6 in.) from zero		

Agency approvals

Intrinsically Safe

C22.2 No. 157	Class I, Division 1, Groups A, B, C and D Class II, Division 1, Groups E, F and G Class III, T4 NEMA Type 4X	EN 60079-11	PTB 10 ATEX 2011 X  II 1/2 G bzw. II 2 G Ex ia IIB T4 bzw. Ex ia IIA T4 Ga/Gb or Gb
GB 3836.4-2010	GYJ14.1052X Ex ia IIB T4 Ga/Gb	FM3610	Class I, Division 1, Groups C and D Class II, Division 1, Groups E, F and G Class III, T4, NEMA Type 4X

MTS Analog setup software

MTS has developed the MTS Setup Software to help customers program and customize their Level Plus Model MC420 transmitter.

The Model MC420 transmitter is programmed through a HART interface. This interface is easily connected to a PC by using a HART-to-Serial converter. The MTS Analog Setup Software allows the user to adjust 'Zero' (4 mA) and 'Span' (20 mA) setpoints and adjust HART parameters.

MTS setup software is shipped with each transmitter order. However, if you require an additional copy or an upgrade to your currently installed setup software, updates are available for download from the following MTS Level Products page at <http://www.mtssensors.com>.

HART® handheld communicator programming

The Level Plus Model MC420 transmitter programming can also be performed by using a handheld HART communicator device such as the *Rosemount® 375 or 475*.

Transmitter calibration

Calibration can also be accomplished without the use of any electronic equipment. MTS supplies a custom setpoint magnet with each MC420 level transmitter. The magnet is used to set the 'Zero' (4 mA) and 'Span' (20 mA) setpoints. Setpoint adjustment locations (*as shown below*) are found at the bottom of the transmitter housing (*as shown below*). Both Zero and Span setting locations are identified with 'Z' (for Zero) and 'S' (for Span). To set the Zero (4 mA) setpoint, adjust the float to the appropriate level and insert the magnet into the circular 'Z' recess. To set the Span (20 mA) setpoint adjust the float to the appropriate level insert the magnet into the circular 'S' recess.

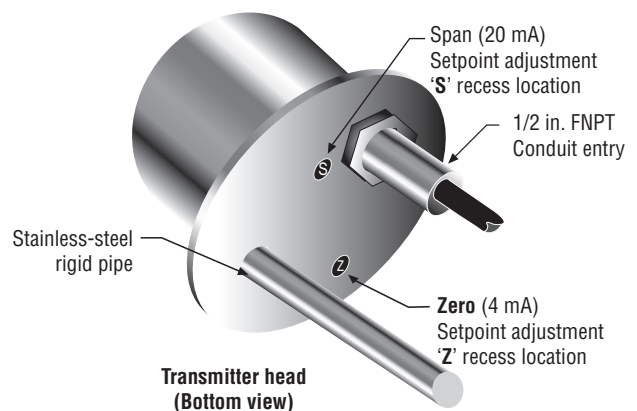

Level Plus® Model MC420 Installation Guideline Rigid Pipe Applications

Product dimensions and mounting

MTS offers the Level Plus Model MC420 transmitter configured with a rigid pipe constructed of 316L stainless steel (*see illustration below*). The rigid pipe configuration can be ordered in lengths from 457 mm (18 in.) to 5486 mm (216 in.). The Model MC420 comes standard with a 3/4 in. MNPT Adjustable fitting as its process connection, which allows the transmitter order length to be adjusted (within a few inches) if the tank height and order length are not exactly equal.

The 'Measuring range' of the MC420 transmitter is equal to the 'Order length' minus the 'Inactive zone' of 76 mm (3.0 in.). The transmitter can be ordered with a single standard product float (*part number 251981-1*), or can include an optional non-standard float (*Refer to the Level Plus Accessories Catalog, document no. 551103 for optional float selections*).

The 'stop collar' option must be ordered separately if you choose a non-standard float. This option is designed to keep the float out of the inactive zone. The placement of the stop collar is dependent on the float and placement of the magnet.

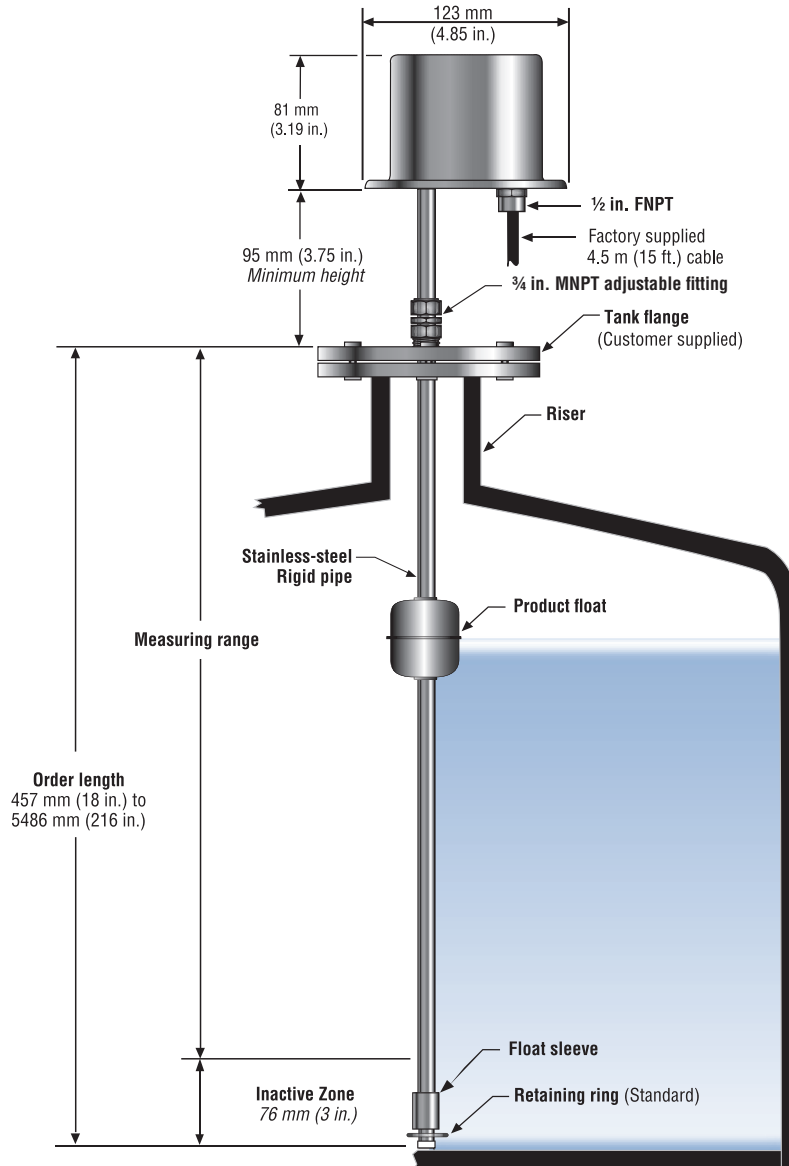

Ordering information

_____ **TRANSMITTER MODEL** _____ =

M	C	4	2	0
---	---	---	---	---

 1 - 5

M-Series Model MC420 liquid-level transmitter
 Comes with one standard product level float (part number 251981-X, see Standard float section below).

_____ **TRANSMITTER ORDER LENGTHS[□]** _____ =

--	--	--

 6 - 8

Length	Code	Length	Code	Length	Code
457 mm (18 in.)	= 018	1829 mm (72 in.)	= 072	3658 mm (144 in.)	= 144
508 mm (20 in.)	= 020	2134 mm (84 in.)	= 084	3962 mm (156 in.)	= 156
610 mm (24 in.)	= 024	2438 mm (96 in.)	= 096	4267 mm (168 in.)	= 168
914 mm (36 in.)	= 036	2743 mm (108 in.)	= 108	4572 mm (180 in.)	= 180
1219 mm (48 in.)	= 048	3048 mm (120 in.)	= 120	4877 mm (192 in.)	= 192
1524 mm (60 in.)	= 060	3353 mm (132 in.)	= 132	5182 mm (204 in.)	= 204
				5486 mm (216 in.)	= 216

□ Standard Range/lengths 457 mm (18 in.) to 5486 mm (216 in.)

_____ **OPTIONAL ACCESSORIES** _____ =

--	--

 9 - 10

FM / CSA Approved

- | | |
|---|--|
| <p>00 = Standard float (part no.: 251981-1)</p> <p>F0 = Non-Standard float ¥‡</p> | <p>T0 = Standard float with Stainless-steel tag</p> <p>FT = Non-standard float with Stainless-steel tag ¥‡</p> |
|---|--|

ATEX / NEPSI Approved

- | | |
|--|--|
| <p>0P = Standard float (part no.: 251981-2) with blue cable</p> | <p>FP = Non-standard float with blue cable ¥‡</p> |
|--|--|

No Approval

- | | |
|--|--|
| <p>0N = Standard float (part no.: 251981-2) with gray cable</p> | <p>FN = Non-standard float with gray cable ¥‡</p> |
|--|--|

¥ Non-standard floats must be ordered separately.
 ‡ Requires a stop collar, part no.: 560369-1 (Which must be ordered separately)

_____ **APPROVAL AGENCY** _____ =

--



 11

- | | |
|--|--|
| <p>F = FM Approval</p> <p>C = CSA Approval</p> <p>X = No Approval</p> | <p>E = ATEX Approval</p> <p>N = NEPSI Approval</p> |
|--|--|

Standard product float and optional hardware

Listed below is the standard float for general applications. Please consult the factory for help in selecting the correct float for your application. For detailed information about all liquid-level product accessories, refer to the 'Level Product Accessories' section of this catalog or 'Level Plus Accessories Catalog, document No. 551103' available in PDF format at <http://mtssensors.com>.

STANDARD PRODUCT FLOAT (INCLUDED) AND OPTIONAL HARDWARE

Standard product float (included)	Pressure	Temp.	Magnet offset	Specific gravity	Material	Weight offset	Part number
	29.3 bar (425 psi)	149 °C (300 °F)	No	0.65	SS	No	251981-1
						Yes	251981-2
Optional hardware							Part number
	Stainless-steel tag (I.D. tag)						250857
	Stainless-steel stop collar (Required when ordering non-standard float options 'FO', 'FT', 'FP' or 'FN')						560369-1

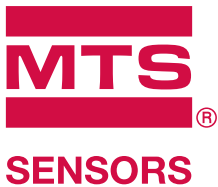

LEGAL NOTICES

Document Part Number:
550752 Revision I (EN) 03/2015

MTS and Temposonics are registered trademarks of MTS Systems Corporation.
All other trademarks are the property of their respective owners.
Printed in USA. Copyright © 2015 MTS Systems Corporation. All Rights Reserved in all media.

LOCATIONS

USA
MTS Systems Corporation
Sensors Division
3001 Sheldon Drive
Cary, N.C. 27513, USA
Tel. +1-919-677-0100
Fax +1-919-677-0200
info.us@mtssensors.com
www.mtssensors.com

GERMANY
MTS Sensor Technologie
GmbH & Co. KG
Auf dem Schüffel 9
58513 Lüdenscheid, Germany
Tel. +49-23 51-95 87 0
Fax +49-23 51-5 64 91
info.de@mtssensors.com
www.mtssensors.com

JAPAN
MTS Sensors Technology Corp.
737 Aihara-machi,
Machida-shi,
Tokyo 194-0211, Japan
Tel. +81-42-775-3838
Fax +81-42-775-5512
info.jp@mtssensors.com
www.mtssensors.com