

# Temposonics®

Magnetostrictive Linear Position Sensors

## ER Start / Stop Data Sheet

- Compact sensor model
- Operating temperature up to +75 °C (+167 °F)
- Ideal for flexible mounting

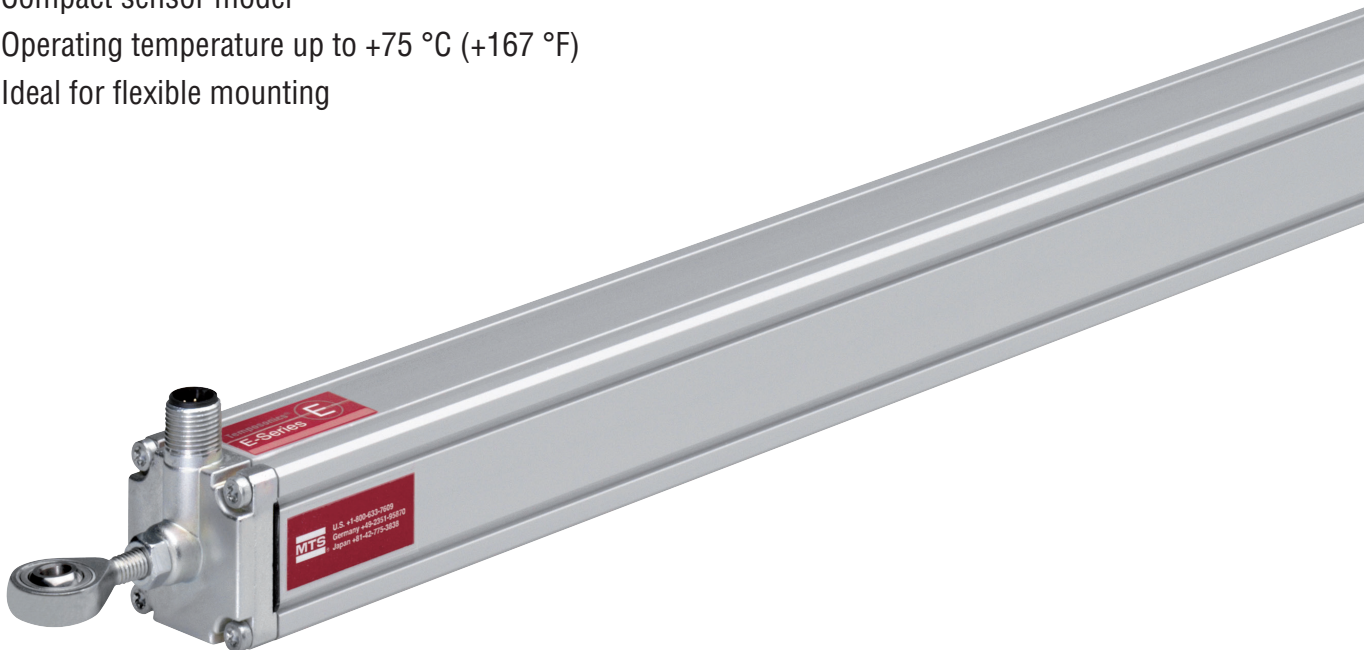

## MEASURING TECHNOLOGY

The absolute, linear position sensors provided by MTS Sensors rely on the company's proprietary Temposonics® magnetostrictive technology, which can determine position with a high level of precision and robustness. Each Temposonics® position sensor consists of a ferromagnetic waveguide, a position magnet, a strain pulse converter and supporting electronics. The magnet, connected to the object in motion in the application, generates a magnetic field at its location on the waveguide. A short current pulse is applied to the waveguide. This creates a momentary radial magnetic field and torsional strain on the waveguide. The momentary interaction of the magnetic fields releases a torsional strain pulse that propagates the length of the waveguide. When the ultrasonic wave reaches the end of the waveguide it is converted into an electrical signal. Since the speed of the ultrasonic wave in the waveguide is precisely known, the time required to receive the return signal can be converted into a linear position measurement with both high accuracy and repeatability.

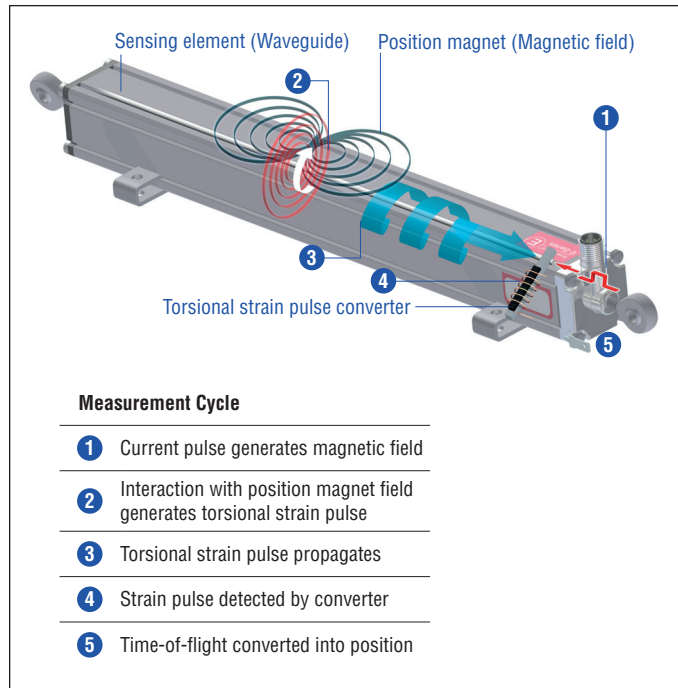

Fig. 1: Time-of-flight based magnetostrictive position sensing principle

## ER SENSOR

Robust, non-contact and wear free, the Temposonics® linear position sensors provide the best durability and precise position measurement feedback in harsh industrial environments. Measurement accuracy is tightly controlled by the quality of the waveguide manufactured exclusively by MTS Sensors.

The Temposonics® ER has an aluminum rod-and-cylinder design where the rod can extend and retract from the sensor housing to measure linear position. Inside, a magnet is secured to the end of the rod and remains protected within the sensor electronics housing. Accessory rod ends are available for attaching the rod to the machine's moving part. The rod-and-cylinder sensor design can be installed in any orientation, and provides a convenient and versatile position feedback solution. Typical fields of applications are printing and paper industry, machine tools and plastics industry as well as control systems.



Fig. 2: Typical application: Paper industry

## TECHNICAL DATA

Output	
Start/Stop	RS-422 differential signal Serial parameter upload available for: stroke length, offset, gradient, status, serial number and manufacturer number.
Measured value	Position
Measurement parameters	
Resolution	Controller dependent
Cycle time	Controller dependent
Linearity	≤ ±0.02 % F.S. (minimum ±60 μm)
Repeatability	≤ ±0.005 % F.S. (minimum ±20 μm)
Operating conditions	
Operating temperature	-40...+75 °C (-40...+167 °F)
Humidity	90 % rel. humidity, no condensation
Ingress protection <sup>1,2</sup>	IP67 (if mating connectors are correctly fitted)
Shock test	100 g (single shock) IEC standard 60068-2-27
Vibration test	5 g / 10...2000 Hz IEC standard 60068-2-6 (resonance frequencies excluded)
EMC test	Electromagnetic emission according to EN 61000-6-3 Electromagnetic immunity according to EN 61000-6-2 The sensor meets the requirements of the EC directives and is marked with <b>CE</b>
Magnet movement velocity	≤ 5 m/s
Design / Material	
Sensor electronics housing	Aluminum
Guided driving rod	Aluminum
Stroke length	50...1500 mm (2...60 in.)
Mechanical mounting	
Mounting position	Any
Mounting instruction	Please consult the technical drawings and the brief instructions (document number: <a href="#">551684</a> )
Electrical connection	
Connection type	M12 (8 pin) male connector
Operating voltage	+24 VDC (-15 / +20 %); UL recognition requires an approved power supply with energy limitation (UL 61010-1), or Class 2 rating according to the National Electrical Code (USA) / Canadian Electrical Code.
Ripple	≤ 0.28 V <sub>pp</sub>
Current consumption	50...100 mA
Dielectric strength	500 VDC (DC ground to machine ground)
Polarity protection	Up to -30 VDC
Overvoltage protection	Up to 36 VDC

1/ The IP rating is not part of the UL recognition

2/ The IP rating IP67 is only valid for the sensor electronics housing, as water and dust can get inside the profile

## TECHNICAL DRAWING

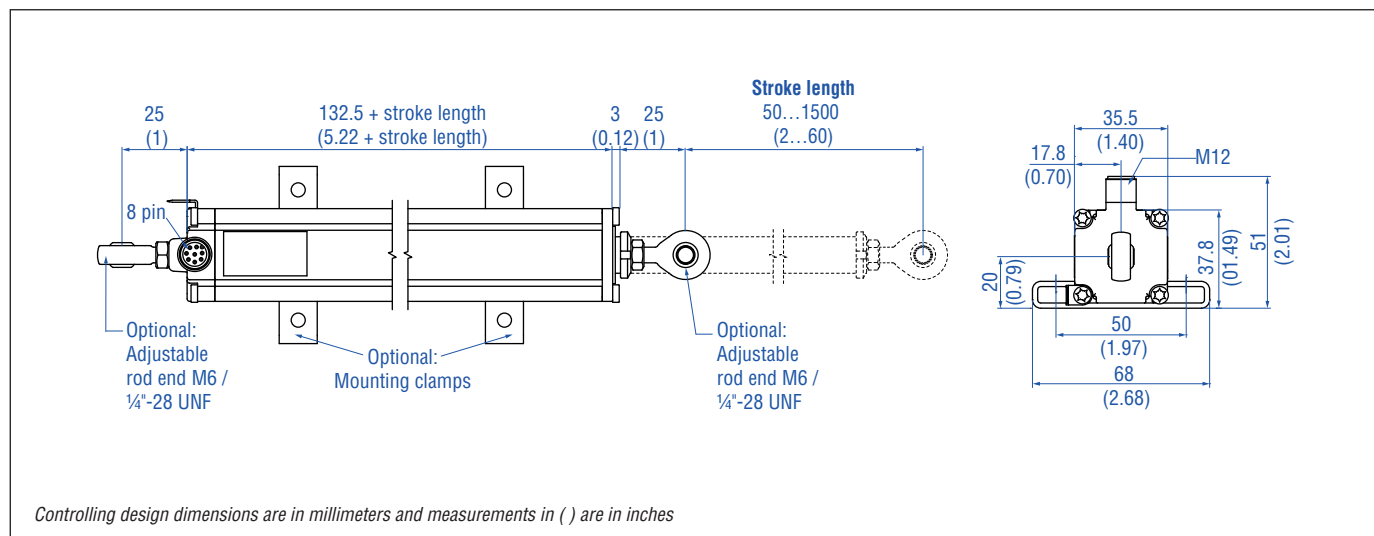

## CONNECTOR WIRING

D84

M12 A-coded	Pin	Function
	1	Start (+)
	2	Start (-)
	3	Stop (+)
	4	Stop (-)
	5	Not connected
	6	Not connected
	7	+24 VDC (-15 / +20 %)
	8	DC Ground (0 V)

**FREQUENTLY ORDERED ACCESSORIES** – Additional options available in our [Accessories Guide](#) 551444

**Cable connectors<sup>3</sup>** **Cord sets**

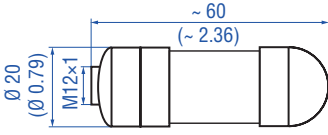
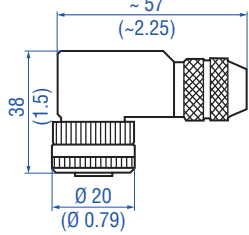
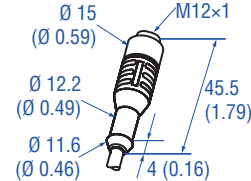
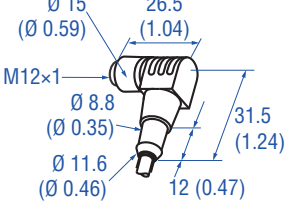
			
<p><b>M12 (8 pin) female, straight</b> Part no. 370 694</p> <p>Housing: GD-ZnAL / IP67 Termination: Screw; 0.75 mm<sup>2</sup> Contact insert: CuZn Operating temperature: -25...+90 °C (-13...+194 °F) Cable Ø: 4...9 mm (0.16...0.35 in.) Fastening torque: 0.6 Nm</p>	<p><b>M12 (8 pin) female, angled</b> Part no. 370 699</p> <p>Housing: GD-ZnAL / IP67 Termination: Screw; max. 0.5 mm<sup>2</sup> Contact insert: CuZn Operating temperature: -25...+85 °C (-13...+185 °F) Cable Ø: 6...8 mm (0.24...0.31 in.) Fastening torque: 0.6 Nm</p>	<p><b>M12 (8 pin) female, straight</b> Part no. 370 674</p> <p>Ingress protection: IP67 Cable: Shielded, pigtail end Cable length: 5 m (16.4 ft.)</p>	<p><b>M12 (8 pin) female, angled</b> Part no. 370 676</p> <p>Ingress protection: IP67 Cable: Shielded, pigtail end Cable length: 5 m (16.4 ft.)</p>

**Rod ends**

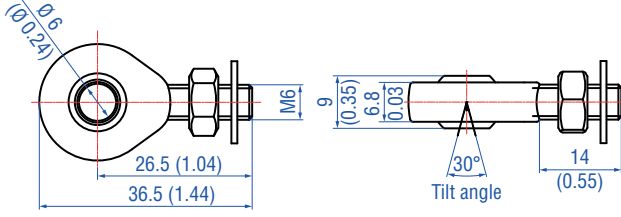
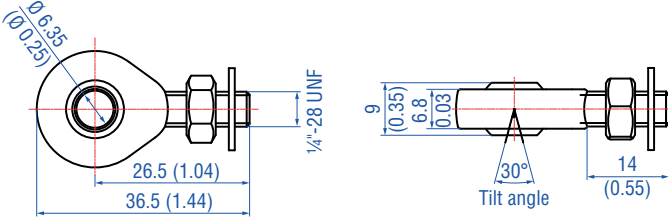
	
<p><b>Rod end with M6 thread (for metric stroke length measurement)</b> Part no. 254 210</p>	<p><b>Rod end with 1/4"-28 UNF thread (for US customary stroke length measurement)</b> Part no. 254 235</p>

**Mounting clamp**

<p><b>4 Holes</b> Ø 5.4 (Ø 0.21) 31 (1.22) 9 (0.35)</p>  <p><b>Mounting clamp width:</b> 14.6 (0.57)</p>
---

<p><b>Mounting clamp</b> Part no. 403 508</p> <p>Material: Edelmetall 1.4301 / 1.4305 (AISI 304 / 303)</p>
--

<sup>3</sup>/ Follow the manufacturer's mounting instructions  
Controlling design dimensions are in millimeters and measurements in ( ) are in inches

## ORDER CODE

1	2	3	4	5	6	7	8	9	10	11	12	13	14
E	R							D	8	4	1	R	3
a		b	c					d			e	f	

<b>a</b>	<b>Sensor model</b>
E R	Aluminum cylinder with a guided driving rod

<b>b</b>	<b>Design</b>
M	Inside thread M6 at end of rod (For metric stroke length measurement)
S	Inside thread 1/4"-28 UNF at end of rod (For US customary stroke length measurement)

<b>c</b>	<b>Stroke length</b>
X X X X M	0050...1500 mm
X X X X U	002.0...060.0 in.

Standard stroke length (mm)\*

Stroke length	Ordering steps
50 ... 500 mm	25 mm
500...1500 mm	50 mm

Standard stroke length (in.)\*

Stroke length	Ordering steps
2...22 in.	1.0 in.
22...60 in.	2.0 in.

<b>d</b>	<b>Connection type</b>
D 8 4	M12 (8 pin) male connector

<b>e</b>	<b>Operating voltage</b>
1	+24 VDC (-15 / +20 %)

<b>f</b>	<b>Output</b>
R 3	Start / Stop with sensor parameters upload function

## DELIVERY



Sensor

Accessories have to be ordered separately.

Select mounting accessories regarding your application:

- 1 or 2 rod ends M6 / 1/4"-28 UNF or / and
- 2 mounting clamps up to 1250 mm (50 in.) stroke length, 3 mounting clamps for 1500 mm (60 in.) stroke length

Manuals & Software available at:  
[www.mtssensors.com](http://www.mtssensors.com)

\* / Non standard stroke lengths are available; must be encoded in 5 mm / 0.1 in. increments

**UNITED STATES** 3001 Sheldon Drive  
MTS Systems Corporation Cary, N.C. 27513  
Sensors Division Phone: +1 919 677-0100  
E-mail: info.us@mtssensors.com

---

**GERMANY** Auf dem Schüffel 9  
MTS Sensor Technologie 58513 Lüdenscheid  
GmbH & Co. KG Phone: +49 2351 9587-0  
E-mail: info.de@mtssensors.com

---

**ITALY** Phone: +39 030 988 3819  
Branch Office E-mail: info.it@mtssensors.com

---

**FRANCE** Phone: +33 1 58 4390-28  
Branch Office E-mail: info.fr@mtssensors.com

---

**GREAT BRITAIN** Phone: +44 79 44 15 03 00  
Branch Office E-mail: info.uk@mtssensors.com

---

**CHINA** Phone: +86 21 6485 5800  
Branch Office E-mail: info.cn@mtssensors.com

---

**JAPAN** Phone: +81 42 707 7710  
Branch Office E-mail: info.jp@mtssensors.com

---

**Document Part Number:**  
551680 Revision A (EN) 02/2018



[www.mtssensors.com](http://www.mtssensors.com)