



Part no.: 540353
BT-SET-240CCS-E
Mounting bracket set

Figure can vary

Contents

- Technical data
- Dimensioned drawings

Part no.: 540353 – BT-SET-240CCS-E – Mounting bracket set

Technical data

Basic data

Suitable for	MLD-M002, MLD-M003 deflecting mirror
--------------	--------------------------------------

Mechanical data

Type of fastening, at system	Through-hole mounting
------------------------------	-----------------------

Type of fastening, at device	Clampable
------------------------------	-----------

Type of mounting device	Shock absorber Turning, 240°
-------------------------	---------------------------------

Mounting device material	Plastic Metal
--------------------------	------------------

Classification

eCl@ss 8.0	27279202
------------	----------

eCl@ss 9.0	27273701
------------	----------

ETIM 5.0	EC003015
----------	----------

ETIM 6.0	EC003015
----------	----------

Dimensioned drawings

All dimensions in millimeters

BT-SET-240CS-E swivel mount

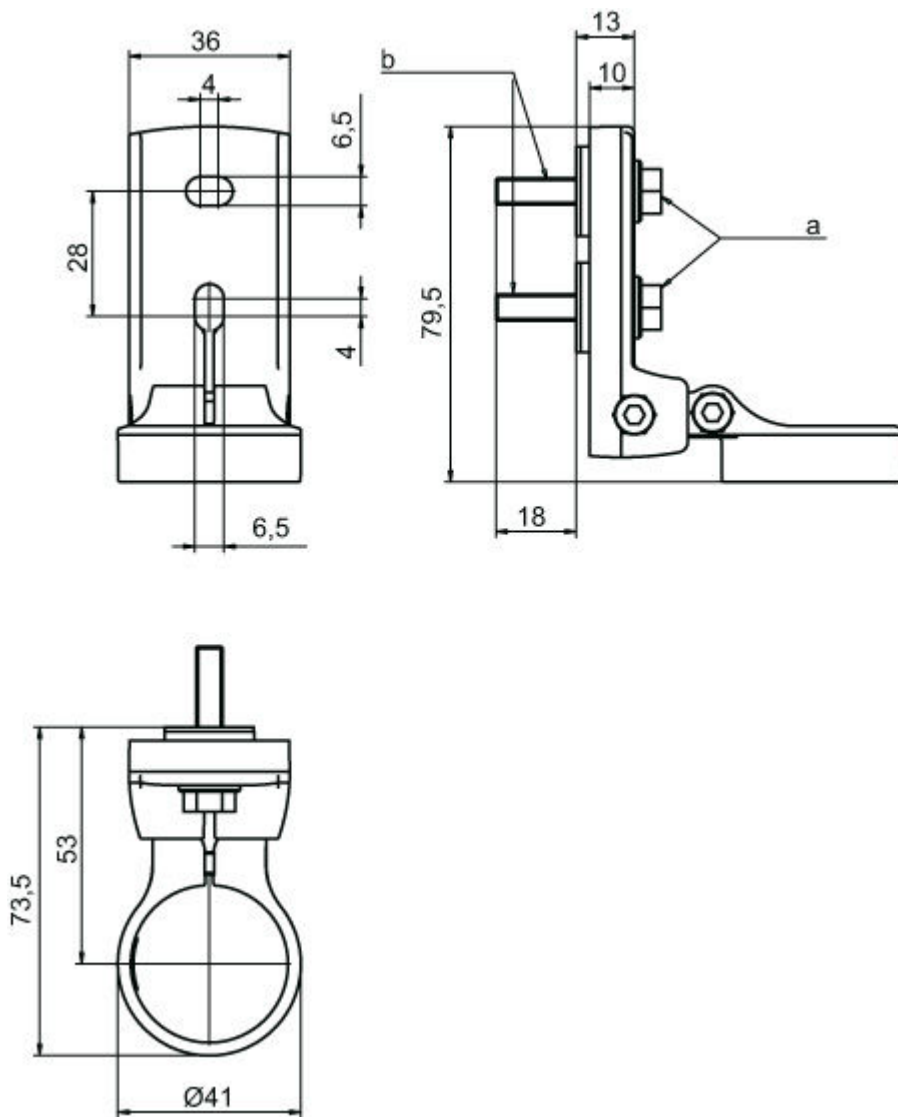

- a M6 screw
- b Shock absorber, M6 thread

Mounting dimensions

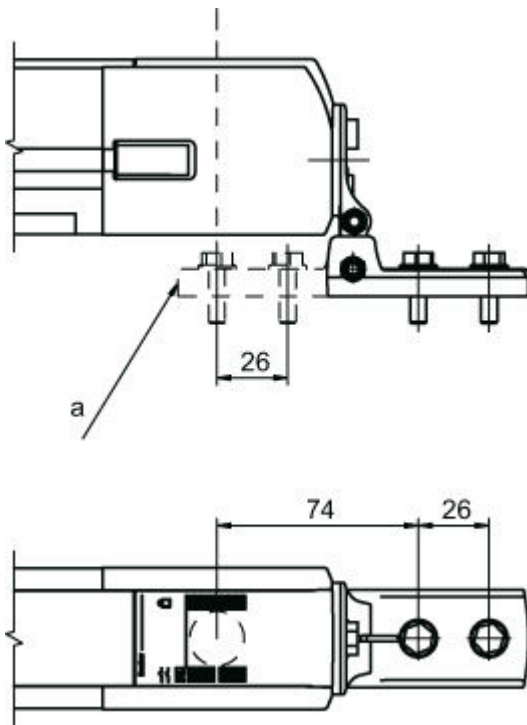

a Alternative mounting variant

Mounting variants

