



Figure can vary

Part no.: 529618
UM60-1800
Deflecting mirror

Contents

- Technical data
- Dimensioned drawings
- Accessories

Part no.: 529618 – UM60-1800 – Deflecting mirror

Technical data

Basic data

Series	UM
Type, columns and mirrors	Deflecting mirror

Mechanical data

Dimension (W x H x L)	25 mm x 68 mm x 1,870 mm
Net weight	3,420 g
Housing color	Yellow, RAL 1021
Type of fastening	Groove mounting Swivel mount
Suitable for sensor	MLC 500, MLC 300 safety light curtains
Protected field height up to	1,800 mm
Mirror length	1,860 mm

Classification

Customs tariff number	70099200
eCl@ss 8.0	27279207
eCl@ss 9.0	27273605
ETIM 5.0	EC002467
ETIM 6.0	EC002467

Dimensioned drawings

All dimensions in millimeters

Mirror

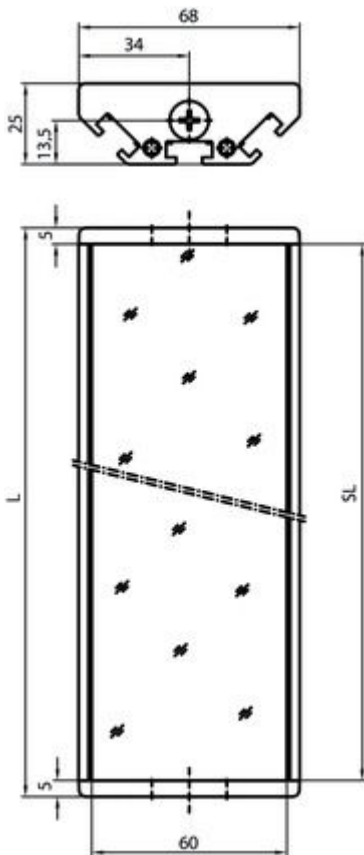

L Length = 1870 mm
SL Mirror length = 1860 mm

Mounting distances



A Max. 500 mm

Mounting with BT-UM60 standard bracket

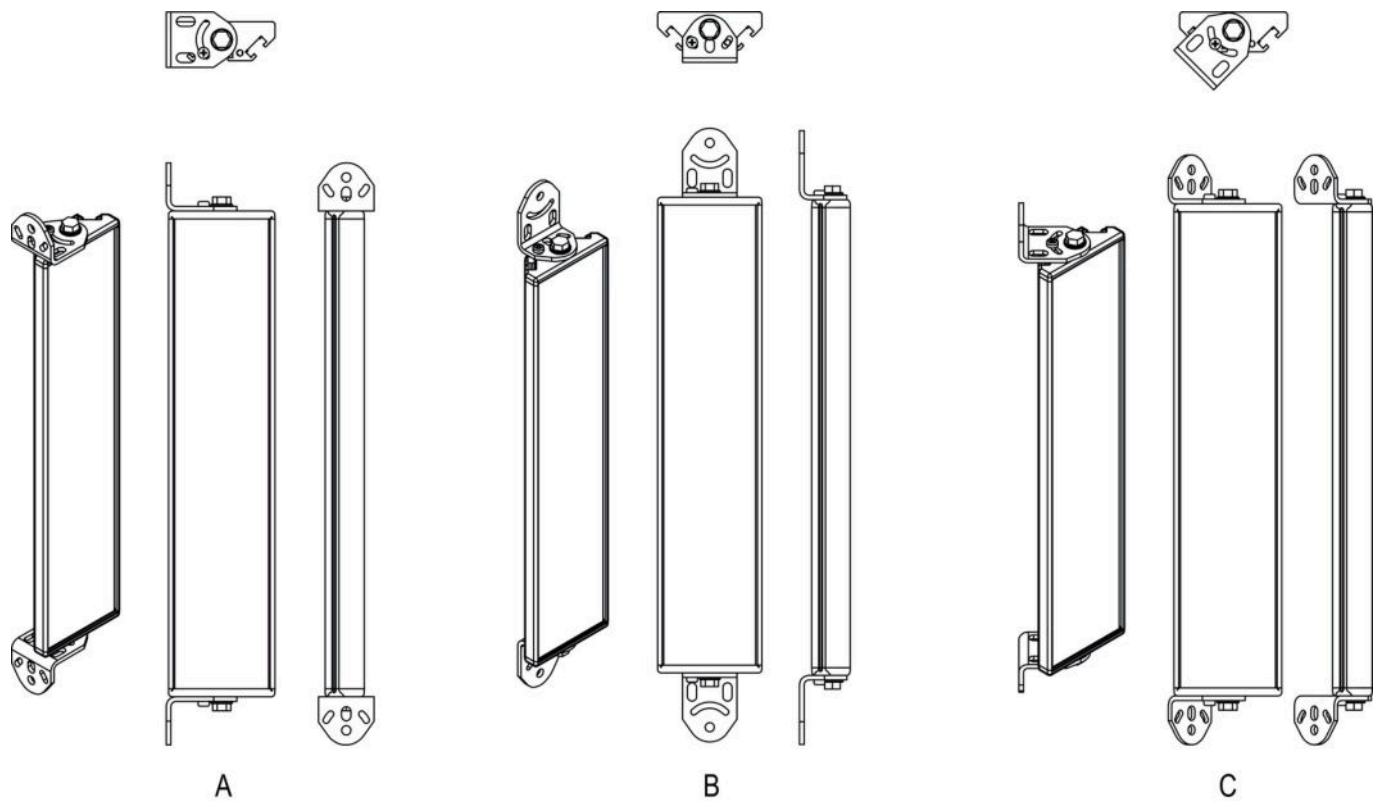

- A Lateral
- B Rear side
- C Adjustable at an angle (0 - 90°)

Mounting with BT-SSD swiveling mounting bracket

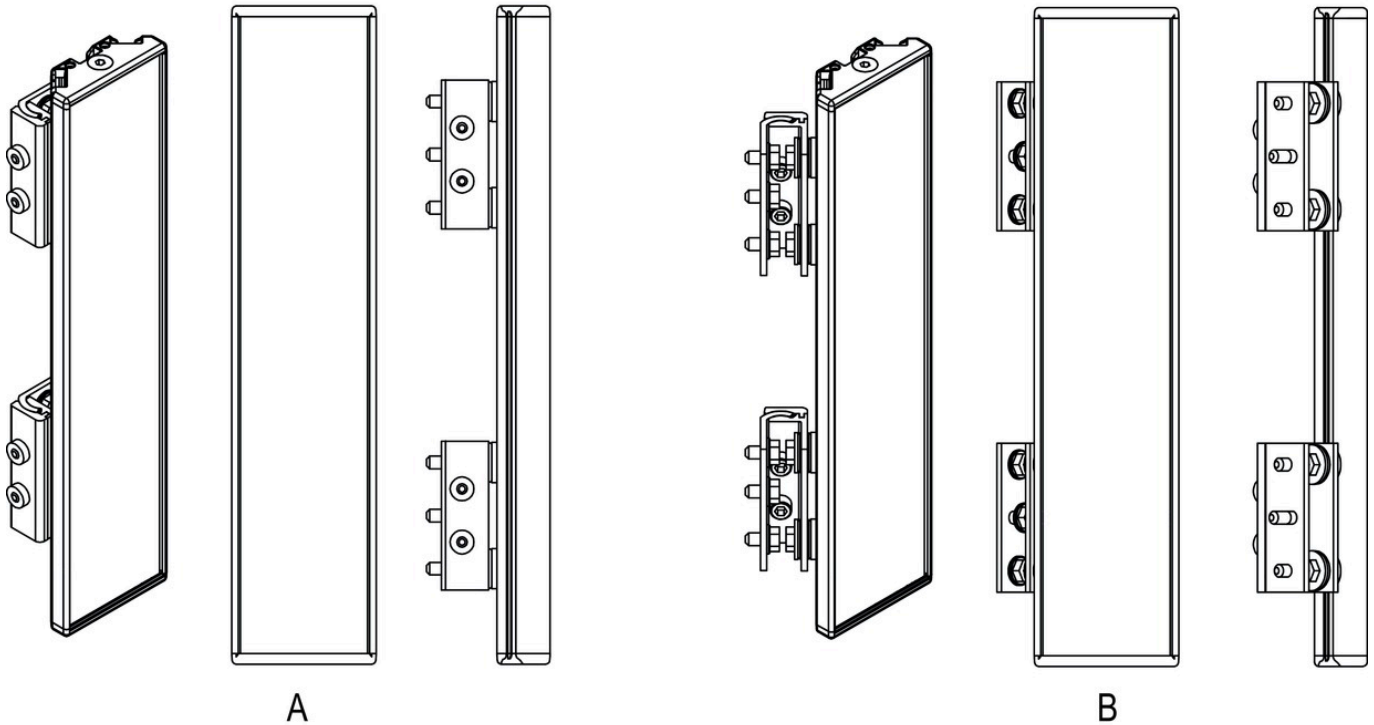
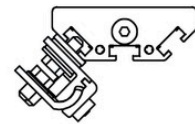
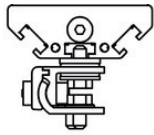

A Rear side
B Lateral 45°





Accessories

Mounting technology - Mounting brackets

	Part no.	Designation	Article	Description
	560120	BT-2S	Mounting bracket set	Fastening, at system: Through-hole mounting Mounting bracket, at device: Screw type Material: Metal
	430105	BT-2UM60	Mounting bracket	Fastening, at system: Through-hole mounting Mounting bracket, at device: Screw type Material: Metal

Part no.: 529618 – UM60-1800 – Deflecting mirror

Mounting technology - Other

	Part no.	Designation	Article	Description
	424422	BT-2SB10	Mounting bracket set	Contains: 2x BT-SB10 Design of mounting device: Mounting clamp Fastening, at system: Through-hole mounting Mounting bracket, at device: Clampable, On the lateral C-groove Type of mounting device: Swiveling Swivel range: -8 ... 8 ° Material: Metal
	424423	BT-2SB10-S	Mounting bracket set	Contains: 2x BT-SB10-S Design of mounting device: Mounting clamp Fastening, at system: Through-hole mounting Mounting bracket, at device: Clampable, On the lateral C-groove Type of mounting device: Swiveling with vibration damper Swivel range: -8 ... 8 ° Material: Metal Shock absorber: Yes
	429058	BT-2SSD	Mounting bracket set	Fastening, at system: Through-hole mounting Mounting bracket, at device: Groove mounting, Clampable, Screw type Type of mounting device: Swiveling Material: Metal
	429049	BT-2SSD-270	Mounting bracket set	Fastening, at system: Through-hole mounting Mounting bracket, at device: Screw type, Clampable, Groove mounting Type of mounting device: Swiveling Material: Metal