

PRK 55 Ex Retro-reflective photoelectric sensors with polarization filter for bottles

en 03-2017/02 50113749-01

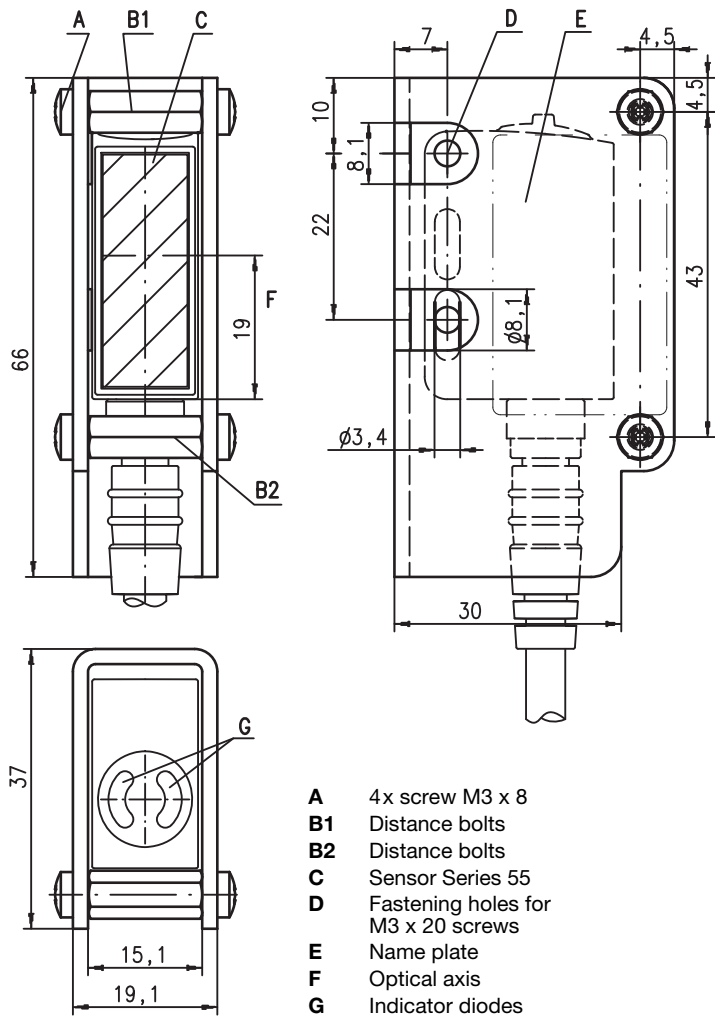

Dimensioned drawing



- A** 4x screw M3 x 8
- B1** Distance bolts
- B2** Distance bolts
- C** Sensor Series 55
- D** Fastening holes for M3 x 20 screws
- E** Name plate
- F** Optical axis
- G** Indicator diodes

- Polarized retro-reflective photoelectric sensor, autocollimation optics with visible red light
- Particularly suited for highly transparent bottles (PET and glass)
- 316L stainless steel housing in WASH-DOWN-Design
- Scratch resistant and non-diffusive plastic front cover
- Easy adjustment via lockable teach button or teach input
- Certification
 - ⊕ II 3G Ex nA op is IIB T4 Gc X
 - ⊕ II 3D Ex tc IIIC T70°C Dc IP67 X

Electrical connection

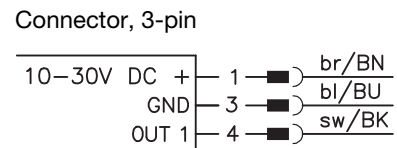
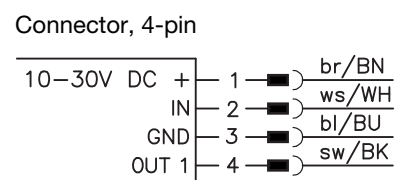

- Observe the notices for installation and commissioning!
- Do not disconnect the sensor connection within the potentially explosive area while under voltage!

Accessories:

- (available separately)
- Cables with M8 connector

Attention!

Only use cables with axial (straight) plug outlet (see dimensioned drawing).

We reserve the right to make changes • PAL_PRK55_Ex_en_50113749_01.fm

Specifications

Optical data

Typ. op. range limit (TK(S) 100x100) ¹⁾ 0 ... 3.5m
 Operating range ²⁾ see tables
 Light source ³⁾ LED (modulated light)
 Wavelength 620nm (visible red light, polarized)

Timing

Switching frequency 1000Hz
 Response time 0.5ms
 Delay before start-up ≤ 300ms

Electrical data

Operating voltage U_B 10 ... 30VDC (incl. residual ripple)
 Residual ripple ≤ 15% of U_B
 Open-circuit current ≤ 18mA
 Switching output .../6D.42 ⁴⁾ 1 push-pull switching output
 OUT1 (pin 4): PNP dark switching, NPN light switching
 .../6.42 ⁴⁾ 1 push-pull switching output
 OUT1 (pin 4): PNP light switching, NPN dark switching
 IN (pin 2): teach input
 light/dark reversible
 ≥ ($U_B - 2V$) / ≤ 2V
 max. 100mA
 setting via teach-in

Function characteristics
 Signal voltage high/low
 Output current
 Operating range

Indicators

Green LED ready
 Yellow LED light path free
 Yellow LED, flashing light path free, no performance reserve ⁵⁾

Mechanical data

Housing AISI 316L stainless steel, DIN X2CrNiMo17132, W.No 1.4404
 Protective housing stainless steel AISI 303, DIN X8CrNiS18-9, W.Nr 1.4305
 Optics cover coated plastic (PMMA), scratch resistant and non-diffusive
 Operation plastic (TPV-PE), non-diffusive
 Weight with M8 connector: 130g
 Connection type M8 connector, 3-pin

Environmental data

Ambient temp. (operation/storage) -20°C ... +50°C / -30°C ... +70°C
 Protective circuit ⁶⁾ 2, 3
 VDE safety class ⁷⁾ III
 Protection class IP 67
 Light source exempt group (in accordance with EN 62471)
 Standards applied IEC 60947-5-2

Explosion protection

Certification (CENELEC) Ex II 3G Ex nA op is IIB T4 Gc X
 Ex II 3D Ex tc IIIC T70 °C Dc IP67 X

- 1) Typ. operating range limit: max. attainable range without performance reserve
- 2) Operating range: recommended range with performance reserve
- 3) Average life expectancy 100,000h at an ambient temperature of 25°C
- 4) The push-pull switching outputs must not be connected in parallel
- 5) Display "no performance reserve" as yellow flashing LED is only available in standard teach setting
- 6) 2=polarity reversal protection, 3=short circuit protection for all transistor outputs
- 7) Rating voltage 50V

Remarks

Operate in accordance with intended use!

- ⚠ This product is not a safety sensor and is not intended as personnel protection.
- ⚠ The product may only be put into operation by competent persons.
- ⚠ Only use the product in accordance with the intended use.

Order guide

	Designation	Part no.
With M8 connector, 3-pin	PRK 55/6D.42-S8.3 Ex	50115207
With M8 connector, 4-pin	PRK 55/6.42-S8 Ex	50119364

Tables

Reflectors in food quality			Operating range
1	TK(S)	100x100	0 ... 3.0m
2	TK	40x60	0 ... 2.0m
3	Tape 6	50x50	0 ... 1.2m
4	TK	20x40	0 ... 1.0m
5	Tape 4	50x50	0 ... 0.5m

1	0		3	3.6
2	0	2.0	2.4	
3	0	1.2	1.4	
4	0	1.0	1.2	
5	0	0.5	0.6	

Pharmaceutical reflectors			Operating range
1	TK(S)	40x60.P	0 ... 1.2m
2	TK	BR53	0 ... 1.0m
3	TK(S)	20x40.P	0 ... 0.7m
4	TK(S)	20.P	0 ... 0.5m
5	MTK(S)	14x23.P	0 ... 0.25m
6	TK	10.P	0 ... 0.2m

1	0		1.2	1.4
2	0		1.0	1.2
3	0	0.7	0.8	
4	0	0.5	0.6	
5	0	0.25	0.3	
6	0	0.2	0.25	

□ Operating range [m]
 ▒ Typ. operating range limit [m]

TK ... = adhesive
 TKS ... = screw type

Diagrams

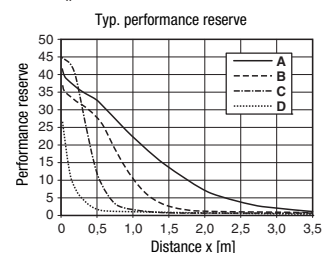
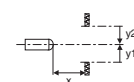
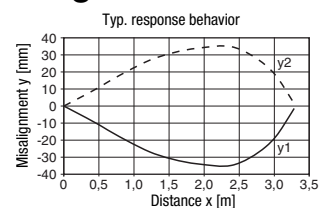

- A TK 100x100
- B TKS 40x60
- C TKS 20x40
- D Tape 4: 50x50

PRK 55 ExRetro-reflective photoelectric sensors with polarization filter for bottles

Sensor adjustment (teach) via teach button



- **The sensor is factory-adjusted for maximum operating range.**
Recommendation: teach only if the desired objects are not reliably detected.
- **Prior to teaching: Clear the light path to the reflector!**
The device setting is stored in a fail-safe way. A reconfiguration following voltage interruption or switch-off is thus not required.

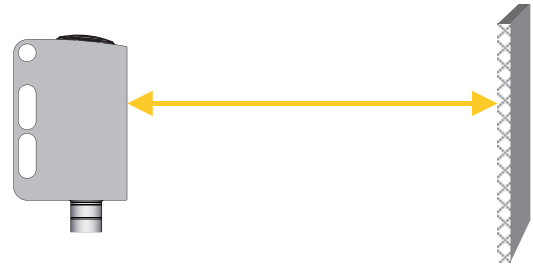

Teach for 11% sensor sensitivity (highly transparent bottles and foils with thickness > 20µm)

- Press teach button until both LEDs flash **simultaneously**.
- Release teach button.
- Ready.



After the teaching, the sensor switches when about 11% of the light beam are covered by the object.

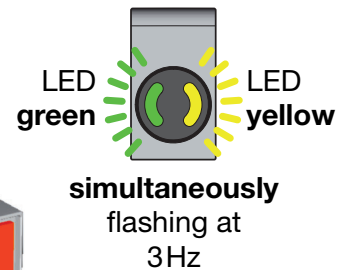
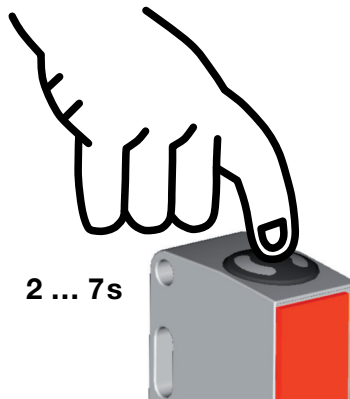

Teach for 18% sensor sensitivity (standard bottles)

- Press teach button until both LEDs flash **alternatingly**.
- Release teach button.
- Ready.



After the teaching, the sensor switches when about 18% of the light beam are covered by the object.

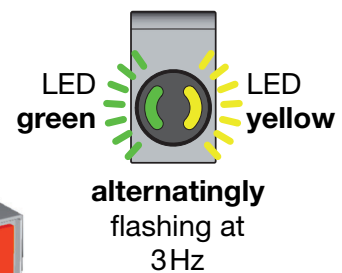
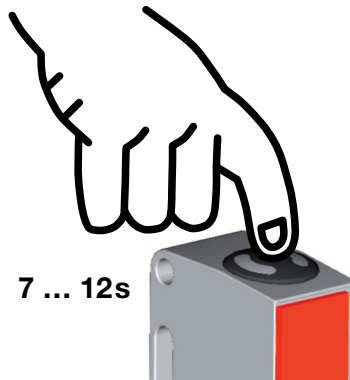

Teaching for maximum operating range (factory setting at delivery)

- Prior to teaching:
Cover the light path to the reflector!
- Press teach button until both LEDs flash **simultaneously**.
- Release teach button.
- Ready.

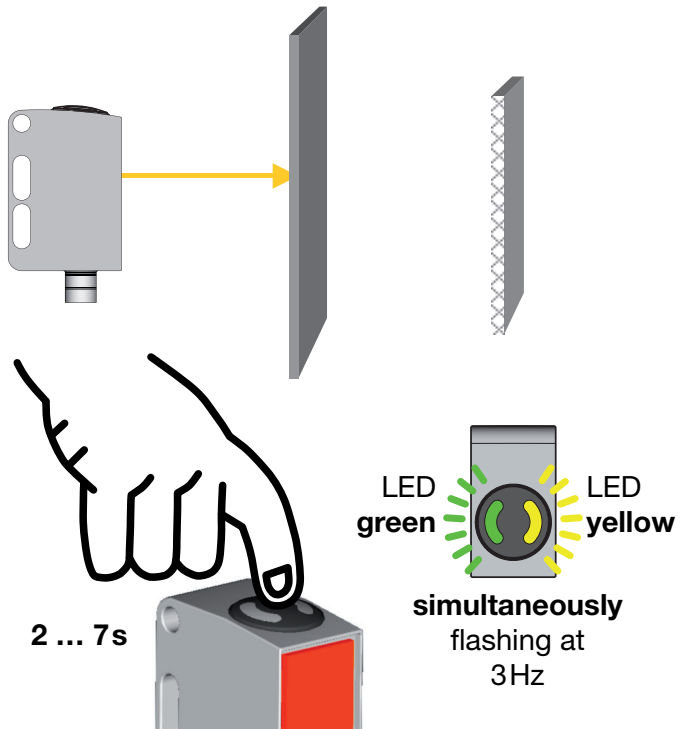

Adjusting the switching behavior of the switching output – light/dark switching

- Press teach button until the green LED flashes. The yellow LED displays the current setting of the switching output:
ON = output light switching
OFF = output dark switching
- Continue to press the teach button in order to change the switching behavior.
- Release teach button.
- Ready.

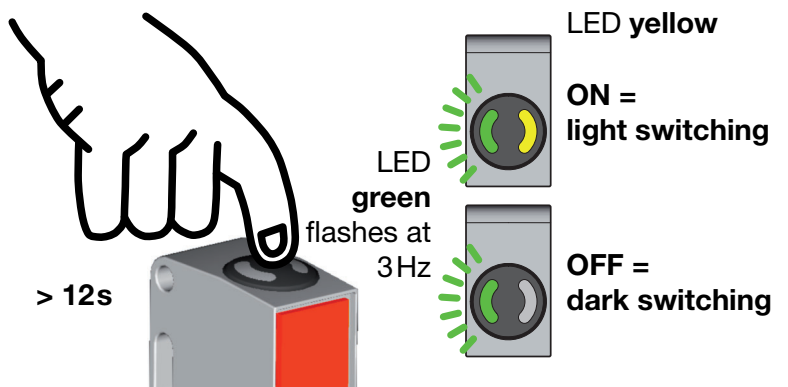

PRK 55 ExRetro-reflective photoelectric sensors with polarization filter for bottles

Notices for the safe use of sensors in potentially explosive areas

The valid range encompasses devices of Group II, Category 3, Zones 2 ("Gas Ex") and 22 ("Dust Ex").



- Check whether the equipment classification corresponds to the requirements of the application.
- A safe operation is only possible if the equipment is used properly and for its intended purpose.
- Electrical equipment may endanger humans and (where applicable) animal health, and may threaten the safety of goods if used incorrectly or under unfavorable conditions in potentially explosive areas.
- The applicable national regulations (e.g. EN 60079-14) for the configuration and installation of explosion-proof systems must be observed.

Installation and Commissioning

- The devices must only be installed and commissioned by trained electricians. They must be aware of the regulations and operation of explosion-proof equipment.
- Static charge on plastic surfaces must be avoided.
- To prevent unintentional separation under voltage, devices with connector (e.g. Series 46B) must be equipped with a safeguard or a mechanical interlocking guard (e.g. K-V M12-Ex, part no. 50109217). The warning sign "Do not disconnect under voltage" that is supplied with the device must be attached to the sensor or its mounting bracket so that it is clearly visible.
- Devices with terminal compartment lid (e.g. Series 96) must only be commissioned if the terminal compartment lid of the device is properly sealed.
- Connection cables and connectors must be protected from excessive or unintended pulling or pushing strain.
- Prevent dust deposits from forming on the devices.
- Metallic parts (e.g. housing, mounting devices) are to be integrated into the potential equalization to prevent electrostatic charge.

Maintenance

- No changes may be made to explosion-proof devices.
- Repairs may only be performed by persons trained for such work or by the manufacturer.
- Defective devices must be replaced immediately.
- Cyclical maintenance is generally not necessary.
- Depending on the environmental conditions, it may occasionally be necessary to clean the optical surfaces of the sensors. This cleaning must only be performed by persons trained for this task. We recommend using a soft, damp cloth. Cleaning agents that contain solvents must not be used.

Chemical resistance

- The sensors demonstrate good resistance against diluted (weak) acids and bases.
- Exposure to organic solvents is possible only under certain circumstances and only for short periods of time.
- Resistance to chemicals must be examined on a case by case basis.

Special conditions

- The sensor must be removed from the protective housing in order to connect the M8 connector. After the connection has been established, the sensor must be installed back into the protective housing properly. Operation without protective housing is not permitted.
- If the sensor is connected to the M8 connector and installed properly in the protective housing, the connector can no longer be unintentionally separated. Further mechanical protective measures are therefore not necessary.
- The devices must be installed in such a way that they are protected from direct exposure to UV rays (sunlight).

Application notes



- For glossy surfaces (e.g. metals), the light beam should not be incident on the object surface at a right angle. A slight inclination is sufficient for preventing undesired direct reflections. This may result in a reduction in the scanning range.
- Objects should only be moved in laterally from the right or left. Moving in objects from the connector side or operating side is to be avoided.
- Outside of the scanning range, the sensor operates as an energetic diffuse reflection light scanner. Light objects can still be reliably detected up to the scanning range limit.
- The sensors are equipped with effective measures for the maximum avoidance of mutual interference should they be mounted opposite one another. Opposite mounting of multiple sensors of the same type should, however, absolutely be avoided.

PRK 55 ExRetro-reflective photoelectric sensors with polarization filter for bottles

Mounting instructions

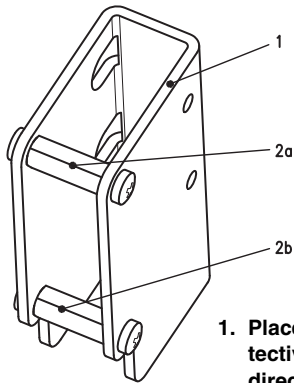

1. Place device in the protective housing in the direction of the arrow.

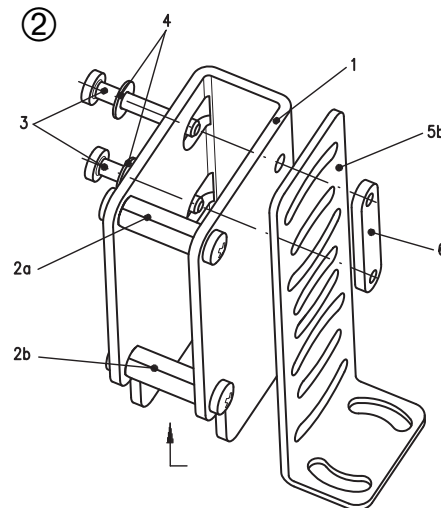
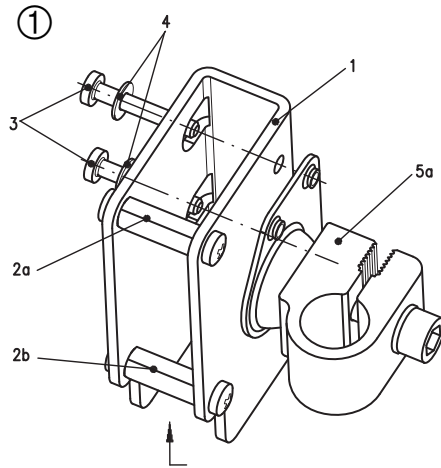
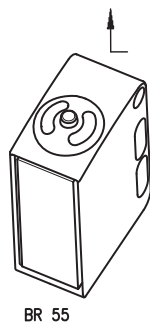

2. Fit fastening screws (item 3) with washers (item 4) according to diagrams ①, ②, ③ depending on the installation situation, push through the device and securely tighten.

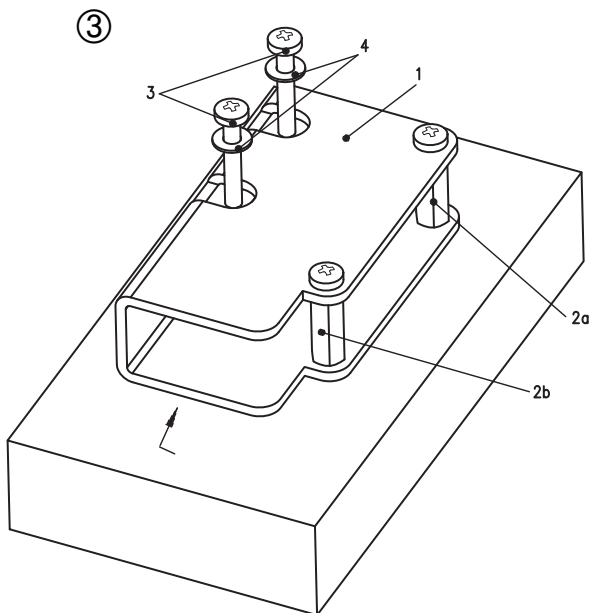

- 1** Protective housing
- 2a, 2b** Distance bolts (mounted)
- 3** Screw M3
- 4** Washer
- 5a, 5b** Mounting devices (e.g. UMS 25, BT 25, ...)
- 6** Plate BT 3

