

Bus-Capable Optical Data Transmission DDLs 200

Technical Description PROFIBUS / RS 485



2 Technical Data

2.1 General technical data

Electrical data	
Supply voltage V_{in}	18 ... 30 V DC
Current consumption without optics heating	approx. 200 mA with 24 V DC (no load at switching output)
Current consumption w. optics heating	approx. 800 mA with 24 V DC (no load at switching output)
Optical data	
Sensing distance	0.2 ... 120 m (DDLs 200/120...) 0.2 ... 200 m (DDLs 200/200...)
Transmission diode	infrared light, wavelength 880 nm
Opening angle	$\pm 0.5^\circ$ to optical axis
Ambient light	> 10000 Lux acc. to EN 60947-5-2 (2000)
Laser safety class	1 acc. to EN 60825-1 (2001)
Input/output	
Input	0 ... 2 V DC: transmitter/receiver deactivated 18 ... 30 V DC: transmitter/receiver activated
Output	0 ... 2 V DC: normal operation Vin - 2 V DC: limited performance reserve output current max. 100 mA, short-circuit proof, protected against surge voltage, transients and overheating
Operating and display elements	
Membrane buttons	change the operating mode
Individual LEDs	indicate voltage supply, operating mode, data traffic
LED strip	bar graph display of the receiving level
Mechanical data	
Housing	aluminium diecast; light inlet/outlet, glass
Weight	approx. 1200 g
Protection class	IP 65 acc. to EN 60529
Environmental conditions	
Operating temperature	-5 °C ... +50 °C without optics heating -30 °C ... +50 °C with optics heating (non-condensing)
Storage temperature	-30 °C ... +70 °C
Air humidity	max. 90% rel. humidity, non-condensing
Vibrations	acc. to EN 60068-2-6
Noise	acc. to EN 60068-2-64
Shock	acc. to EN 60068-2-27 and EN 60068-2-29
EMC	acc. to EN 61326 (1998) + A1 (1999)

3 Mounting / Installation (all device variants)

3.1 Mounting and alignment

An optical data transmission system, consisting of 2 DDLs 200 devices, involves mounting each of the devices on mutually opposing, plane-parallel, flat and usually vertical walls with unobstructed view of the opposing DDLs 200.

Make certain that, at the minimum operating distance A_{min} , the optical axes of the devices are aligned with one another within $\pm A_{min} \cdot 0.01$ to ensure that the transmission/reception beams of the two devices lie within the opening angle. This also applies for rotary transmission.

Note
The opening angle (angle of radiation) of the optics is $\pm 0.5^\circ$ to the optical axis! The horizontal and vertical adjustment angles of the fine alignment with the adjustment screws is $\pm 6^\circ$ for each. The optical transmission path between the DDLs 200s should not be interrupted. If interruptions cannot be avoided, be sure to read the notice in chapter 5.4. Therefore, pay close attention when selecting a suitable mounting location!

Attention!
When laying out a mobile arrangement for a DDLs 200, pay particular attention that the alignment of the devices relative to one another remains unchanged over the transmission path. The transmission can be interrupted by e.g. jolts, vibrations or inclination of the mobile device due to irregularities in the floor or path. **Ensure adequate track stability!**

Mount each device with 4 screws $\varnothing 5$ mm using 4 of the 5 fastening holes in the mounting plate of the device (see chapter 3.2 "Dimensioned drawing").

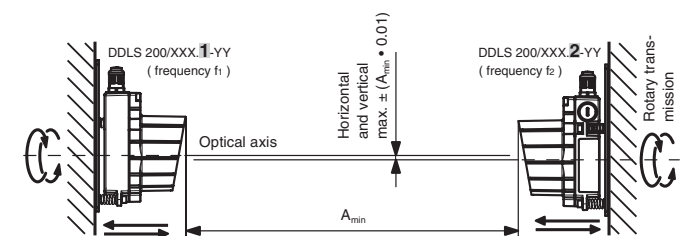

Figure 3.1: Mounting the devices

Note
The fine alignment of the transmission system is performed during commissioning (see chapter 5.3.2 "Fine adjustment"). The position of the optical axis of the DDLs 200 can be found in chapter 3.2.

3.3 Electrical connection

Attention!
Connection of the device and maintenance work while under voltage must only be carried out by a qualified electrician.

If faults cannot be corrected, the device should be removed from operation and protected against possible use.

Before connecting the device, be sure that the supply voltage agrees with the value printed on the nameplate.

The power supply unit used to power the DDLs 200 must have protected electrical separation by way of a safety transformer with double insulation according to EN 60742 (equivalent IEC 60742).

Be sure that the earthing conductor is connected correctly. Error-free operation is guaranteed only when the device is properly earthed.

Described in this section is the electrical connection of the supply voltage, the input and the output. These connections and their functions are identical for all device variants.

The connection of the respective bus system is described in the following chapters.

To establish the electrical connections, you must first remove the red housing top with the optics. To do this, loosen the three housing hex screws. The housing top is now only electrically connected to the base by means of a connector. Carefully pull the housing top straight forward without skewing.

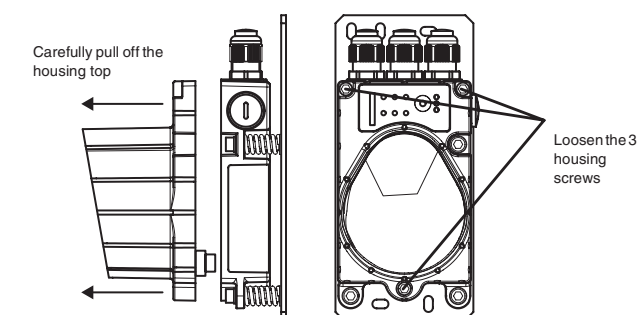

Figure 3.3: Removing the housing top

1 Safety Notices

1.1 Safety standards

The optical DDLs 200 data transmission system was developed, manufactured and tested in accordance with applicable safety standards. It corresponds to the state of the art.

1.2 Intended use

The DDLs 200 optical data transmission system has been designed and developed for the optical transmission of data in the infrared range.



Attention!
The protection of personnel and the device cannot be guaranteed if the device is operated in a manner not corresponding to its intended use.

Areas of application

The DDLs 200 is suitable for the following areas of application:

- Automated high-bay warehouses
- Stationary data transmission between buildings
- Anywhere, where data transmission to and from stationary or moving objects (visual contact) over relatively long distances (up to 200 m) is required.
- Rotary transmission

1.3 Working safely



Attention Laser!
The DDLs 200 data transmission system is an infrared laser device of Laser Class 1 in accordance with EN 60825. Do not look directly at the laser beam at close range!

Laser Class 1 permits the use of optical instruments for the direct observation of the laser beam. The laser beam outlet is located on the front side in the upper third of the optics window.

Observe the legal and local regulations applicable to the operation of laser units.



Attention!
Access and changes to the device, except where expressly described in this operating manual, are not authorised.

2.2 Dimensioned drawing

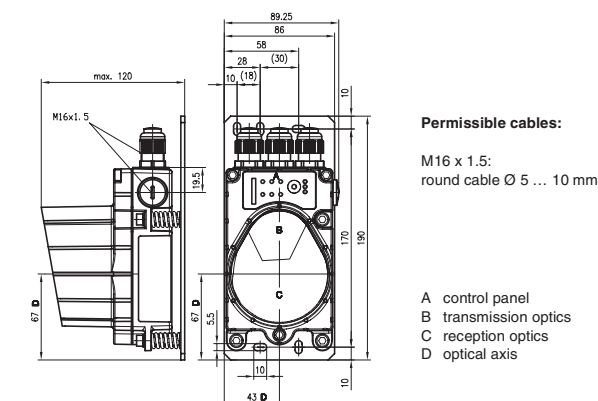

Figure 2.1: Dimensioned drawing DDLs 200 for copper cable

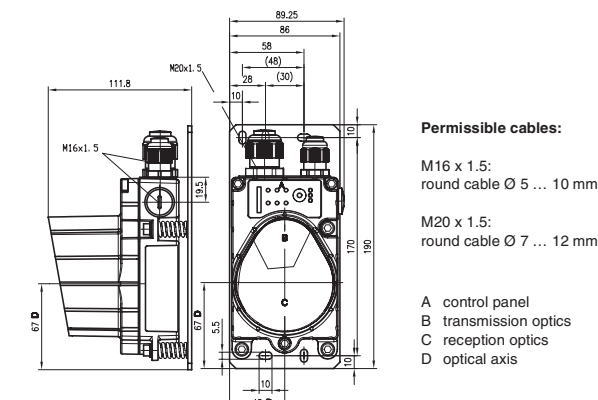

Figure 2.2: Dimensioned drawing DDLs 200 for fibre optic cable

3.2 Arrangement of adjacent transmission systems

To prevent mutual interference of adjacent transmission systems, the following measures should be taken in addition to exact alignment:

- With a frequency-offset arrangement, the distance between two parallel transmission paths must not be less than 300 mm (DDLs 200/120...) or 500 mm (DDLs 200/200...).
- With arrangements using identical frequencies, the distance between two parallel transmission paths must be at least $500 \text{ mm} + \tan(0.5^\circ) \times \text{sensing distance}$ (DDLs 200/200...), or $300 \text{ mm} + \tan(0.5^\circ) \times \text{sensing distance}$ (DDLs 200/120...).

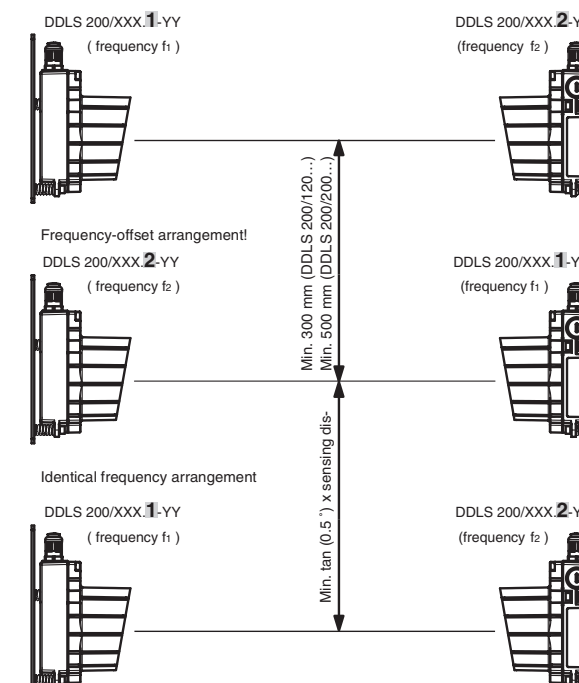

Figure 3.2: Arrangement of adjacent transmission systems

The connection compartment in the housing base with the screwed cable glands is now freely accessible.

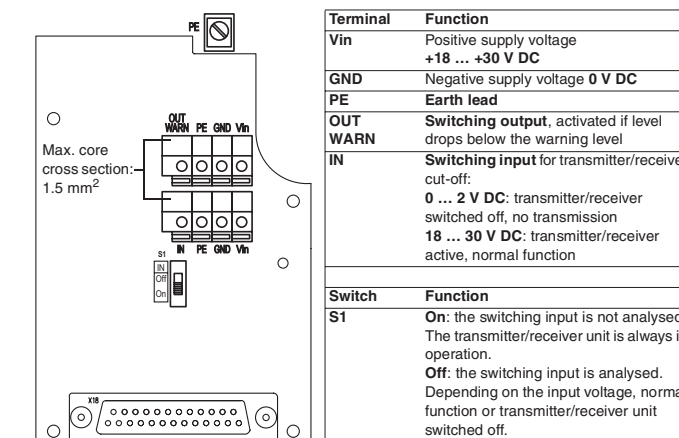

Figure 3.4: Positions of the general, non-bus-specific terminals and switches

3.3.1 Supply voltage

Connect the supply voltage, including the earth lead, to the spring terminals labelled Vin, GND and PE (see figure 3.4).

Note
The connection terminals Vin, GND and PE are provided double to simplify wiring through the supply voltage to other devices.

The earth lead can alternatively be connected at the screw terminal in the housing base (max. core cross section 2.5 mm²).

If you would like to wire through the supply voltage, you should replace the filler plugs on the right side of the housing base with an M16 x 1.5 screwed cable gland and guide the continuing supply voltage cable through this gland. The housing seal is, in this way, ensured (Protection Class IP 65).

The housing top can be removed and replaced while under voltage.

3.3.2 Switching input

The DDLS 200 is equipped with a switching input IN, via which the transmitter/receiver unit can be switched off, i.e. no infrared light is transmitted and at the bus terminals the corresponding bus bias level is present / the bus driver is high resistance.

Input voltage: 0 ... 2 V DC: transmitter/receiver switched off, no transmission (relative to GND) 18 ... 30 V DC: transmitter/receiver active, normal function

For easier operation, the switching input can be activated/deactivated via switch S1:

Position S1: **On** the switching input is not analysed. The transmitter/receiver unit is always in operation (internal preselection of the switching input with Vin). **Off** The switching input is analysed. Depending on the input voltage, normal function or transmitter/receiver unit switched off.

Note! When transmitter/receiver unit is switched off, the system behaves in the same way as in the event of a light beam interruption (see chapter 5.4 "Operation").

The switching input can be used, for example, during a corridor change to completely avoid interference effects from other sensors or the data transmission.

3.3.3 Switching output

The DDLS 200 is equipped with a switching output OUT WARN which is activated if the receiving level in the receiver drops.

Output voltage: 0 ... 2 V DC: operating range (relative to GND) Vin - 2 V DC: warning or shutoff range

The switching output is protected against: short-circuit, surge current, surge voltage, overheating and transients.

Note! The DDLS 200 is still completely functional when the level of the receiving signal drops to the warning signal level. No performance reserve remains.

4.2 Device configuration PROFIBUS

Termination (bus connection, factory setting: 'Off' = no termination)

The PROFIBUS can be terminated via the switch S2 in the DDLS 200. If the termination is active (S2 = On), internal bus resistors are connected as per the PROFIBUS standard and the PROFIBUS is not wired through at terminals 'A' and 'B'.

Activate the termination when the PROFIBUS segment begins or ends at the DDLS 200.

Setting the transmission rate (baud rate, factory setting: '000' = 9.6 kBit/s)

You must set the transmission rate of your PROFIBUS segment using the three DIP switches S3-1 through S3-3. Possible transmission rates are:

- 9.6 kBit/s • 19.2 kBit/s
- 93.75 kBit/s • 187.5 kBit/s
- 500 kBit/s • 1500 kBit/s

Set the transmission rate in accordance with the table printed on the connection circuit board (see figure 4.1).

Changeover PROFIBUS / RS 485 (factory setting: 'Off' = PROFIBUS)

The DDLS 200 has, as a standard function, a repeater function (signal processing) and is, with regard to the PROFIBUS, to be viewed as a repeater.

Note! Please observe the guidelines specified in EN 50170 (Vol. 2) regarding the use of repeaters. The delay time of a data transmission path is maximum 1.5 µs + 1 T_{BR}.

It is also possible to transmit other RS 485 protocols. For PROFIBUS applications, S3-4 should be set to 'Off' ('0'). DIP-switch S3-4 can be used to switch off the repeater function for non-PROFIBUS applications (S3-4 = 'On'). In this case, no signal regeneration takes place; the RS 485 protocol must, however, still provide certain features. Please contact the manufacturer if you would like to use the DDLS 200 for other protocols.

5 Commissioning / Operation (all device models)

5.1 Indicator and operating elements

All DDLS 200 device models have the following indicator and operating elements:

- Bar graph with 10 LEDs
- Operating mode LEDs: AUT, MAN, ADJ
- Operating mode buttons

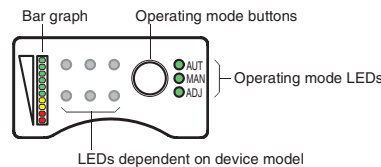

Figure 5.1: Indicator and operating elements common to all DDLS 200 device models

Bar graph

The bar graph displays the quality of the received signal (receiving level) at its own (operating modes "Automatic" and "Manual") or opposing (operating mode "Adjust") DDLS 200 (figure 5.2).

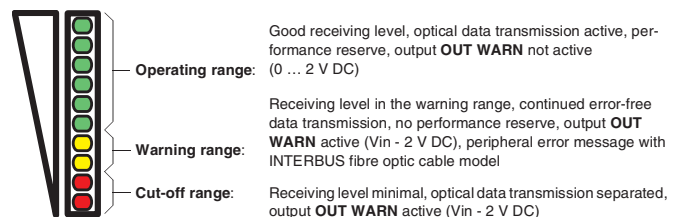

Figure 5.2: Meaning of the bar graph for displaying the receiving level

Operating mode LEDs

The three green LEDs AUT, MAN and ADJ indicate the current operating mode (see chapter 5.2 "Operating modes") of the DDLS 200.

- AUT: operating mode "Automatic"
- MAN: operating mode "Manual"
- ADJ: operating mode "Adjust"

Operating mode buttons

With the operating mode button, you can switch between the three operating modes "Automatic", "Manual" and "Adjust" (see chapter 5.2 "Operating modes").

If the PWR or UL LED fl_hes after switching on, there are two possible causes: either a hardware error has occurred or the transmitter/receiver unit has switched off via the switching input IN (chapter 3.3.2).

If the PWR or UL LED remains dark after switching on, there is either no voltage supply present (check connections and voltage) or a hardware error has occurred.

5.3.2 Fine adjustment

If you have mounted and switched on the two DDLS 200s of a given optical transmission path and they are both in the "Automatic" operating mode, you can perform the fine adjustment of the devices relative to one another with the aid of the three alignment screws.

Note! Note that with "alignment", the transmitter with the beam which is to be positioned as exactly as possible on the opposing receiver is always meant.

At the maximum sensing distance, the bar graph does not show end-scale deflection even with optimal alignment!

The DDLS 200 supports fast and easy fine adjustment. The optimisation of the alignment between the two devices of one transmission path can be performed by just one person. Use the following descriptive steps as a set of numbered instructions:

1. Both devices are located close to one another (> 1 m). Ideally, the bar graphs of both devices display maximum end-scale deflection.
2. Switch both devices to "Manual" (MAN) by pressing the button for a relatively long time (> 2 s). Data transmission remains active, only the internal cut-off threshold is changed to the warning threshold (yellow LEDs).
3. While in the "Manual" operating mode, move until data transmission of the DDLS 200 is interrupted. The devices are not yet optimally aligned with one another.
4. Briefly press the button to switch both devices to the "Adjust" operating mode (ADJ). Data transmission remains interrupted.
5. The devices can now be individually aligned. The result of the alignment can be read directly in the bar graph.
6. When both devices are aligned, briefly pressing the button on one of the devices is enough to switch both back to the "Manual" operating mode (MAN). Data transmission is again active; the vehicle can continue its path. If data transmission is interrupted again, repeat steps 3 through 6.
7. If the data transmission and the alignment are OK through the end of the path of motion, switch both devices back to the "Automatic" (AUT) operating mode by pressing the button for a relatively long time (> 2 s). The optical data transceiver is now ready for operation.

4 PROFIBUS / RS 485

The PROFIBUS model of the DDLS 200 has the following features:

- Electrically isolated interface
- The DDLS does not occupy a PROFIBUS address
- Integrated repeater function (signal processing), can be switched off
- Protocol-independent data transmission, i.e. transmission of the FMS, DP, MPI, FMS/DP mixed operation protocols
- Connectable bus terminator (termination)
- 6 baud rates can be set

4.1 Electrical connection PROFIBUS

The electrical connection to the PROFIBUS is made at the terminals A, B, and COM. The terminals A, B and COM are provided for wiring through the bus.

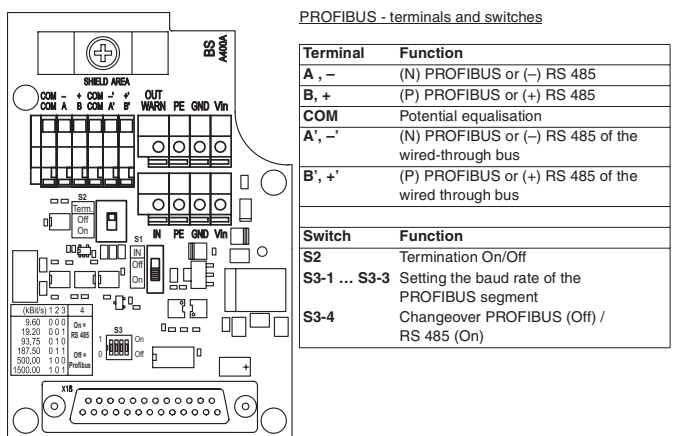

Figure 4.1: Connection circuit board of the PROFIBUS model

Attention! Please be sure to observe the installation requirements (bus cables, cable lengths, shielding, etc.) defined in the PROFIBUS standard EN 50170 (Vol. 2).

4.3 LED Indicators PROFIBUS

In addition to the indicator and operating elements present in all device models (bar graph, buttons, LEDs AUT, MAN, ADJ; see chapter 5.1 "Indicator and operating elements"), the PROFIBUS model also has the following indicators:

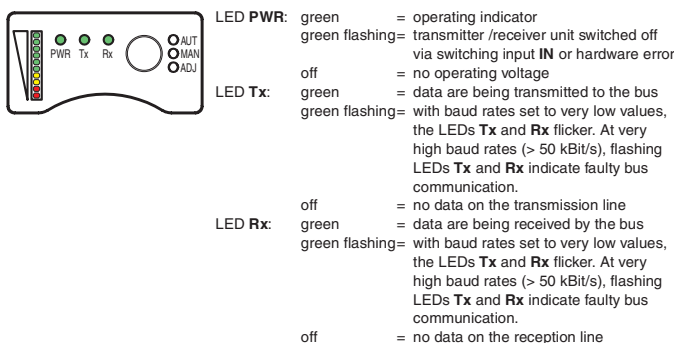

Figure 4.2: Indicator/operating elements for the PROFIBUS model

5.2 Operating modes

The following table provides an overview of the DDLS 200 operating modes.

Operating mode	Description	Optical data transmission	Bar graph assignment
Automatic, AUT LED illuminates	Normal operation	Active	Its own receiving level, display of the alignment quality of the opposing device
Manual, MAN LED illuminates	Adjustment operation, cut-off threshold on higher level	Active	Its own receiving level, display of the alignment quality of the opposing device
Adjust, ADJ LED illuminates	Adjustment operation, cut-off threshold on higher level	Separated	Receiving level of the opposing device, display of the alignment quality of own device

Changing the operating mode

- AUT → MAN** Press the operating mode button for more than 2 seconds. Only the device on which the button was pressed switches to the "Manual" operating mode (MAN LED illuminates).
- MAN → ADJ** Press the operating mode button on one of the two devices. Both devices switch to the "Adjust" operating mode (both ADJ LEDs illuminate) when both were previously in the "Manual" operating mode.
- ADJ → MAN** Press the operating mode button on one of the two devices. Both devices switch to the "Manual" operating mode (both MAN LEDs illuminate).
- MAN → AUT** Press the operating mode button for more than 2 seconds. Only the device on which the button was pressed switches to the "Automatic" operating mode (AUT LED illuminates).

Note! To switch to the "Adjust" (ADJ) operating mode, both devices belonging to a transmission path must first be in the "Manual" (MAN) operating mode. It is not possible to switch directly from the "Automatic" to the "Adjust" operating mode or vice versa.

5.3 Initial commissioning

5.3.1 Switch on device / function check

After applying the operating voltage, the DDLS 200 first performs a self-test. If the self-test is successfully completed, the PWR or UL LED illuminates continuously and the DDLS 200 switches to the "Automatic" operating mode. If the connection to the opposing device exists, data can be transmitted immediately.

5.4 Operation

In running operation ("Automatic" operating mode) the DDLS operates maintenance-free. Only the glass optics need to be cleaned occasionally in the event of soiling. This can be checked by analysing the switching output OUT WARN (with the INTERBUS fibre optic cable model, a peripheral error message is also available). If the output is set, soiling of the DDLS 200's glass optics is often the cause (see chapter 6.1 "Cleaning").

It must still be ensured that the light beam is not interrupted at any time.

Attention! If, during operation of the DDLS 200, the light beam is interrupted or one of the two devices is switched voltage free, the effect of the interruption on the entire network is equivalent to the interruption of a data line!

In the event of an interruption (light beam interruption or switched voltage-free), the DDLS 200 switches off the network to a non-interacting state. The system reactions in the event of an interruption are to be defined together with the supplier of the PLC.

6 Maintenance

6.1 Cleaning

The optical window of the DDLS 200 is to be cleaned monthly or as needed (warning output). To clean, use a soft cloth and a cleaning agent (standard glass cleaner).

Attention! Do not use solvents and cleaning agents containing acetone. Use of improper cleaning agents can damage the optical window.



Leuze Mayser electronic Ltd.
Tel. Int. + 44 (0) 1480/408500
Fax Int. + 44 (0) 1480/403808
E-mail: mail@leuzemayser.co.uk
http://www.leuzemayser.co.uk