

Safety modules

Safety-M compact Basic module	Speed monitoring – SMC2.2	1 axis / 2 encoder systems
--	----------------------------------	-----------------------------------



SMC2.2 is a compact safety module of the Safety-M family with integrated drive monitoring for one axis with 2 encoder systems. This standalone speed monitor (basic module) can be operated without additional safe PLC.

Safety-M compact is the optimal solution for integration in existing safety circuits or for retrofitting old machines. Two encoder solutions (HTL/proximity switch, TTL/RS422, SinCos) are supported for safe speed acquisition



The integrated signal converter and splitter allows an easy connection of controllers, which can operate using the same encoder system. It offers in addition the possibility of issuing an analog rotational speed value, e.g. to replace tachometers or similar.

The device can be parameterized with a removable control and diagnostic display or with the PC software SafeConfig OS6.0. This way, setting and diagnostic can be performed conveniently at the office PC or totally and easily using the intuitive touchpad display in the field.

- Extensive library of pre-configured safe sensors and command devices. This allows easy parameterizing without programming.
- Complete range of speed-related safe drive monitoring functions equivalent to EN 61800-5-2 already integrated in firmware (e.g. SOS, SLS, SSM, STO).
- Different encoder interfaces for TTL/RS422, SinCos and HTL/ Push-Pull/proximity switch, for a wide range of sensors that can be freely combined.
- Integrated signal splitter for SinCos signal forwarding (optional). No complex, interference-sensitive external wiring when the controller is to use the same signals.
- The signal converter can issue the encoder signal as SinCos, TTL/RS422 or as a 4 ... 20 mA analog value.
- Snap-on installation on 35 mm C profile rail.
- 4/2 safe input lines, 8/4 safe shut-off channels, 1 safe potential-free relay open contact.
- Contact multiplication or increase of power capability by external contactors in connection with the device-internal monitoring function for external contacts (EDM).
- LED on the front side indicates operating state.
- Removable control and diagnosis display (optional).
- Free "SafeConfig" parameterization software.

Order code	8 . SMC2 . 2 X A 241			
	<table border="1" style="margin: auto;"> <tr> <td style="font-size: small;">a</td> <td style="font-size: small;">b</td> <td style="font-size: small;">c</td> </tr> </table>	a	b	c
a	b	c		

a Encoder interface
2 = 2 x Sub-D SinCos

b Internal signal splitting
0 = without
S = with

c Analog output
A = 4 ... 20 mA

1) Safety-M compact basic module.
2) Optional control and diagnosis display – to be ordered separately (see the accessories).

Safety modules

Safety-M compact Basic module	Speed monitoring – SMC2.2	1 axis / 2 encoder systems
--------------------------------------	----------------------------------	-----------------------------------

Accessories		Order no.
Control and diagnostic display, OLED touch screen		8.SMCB.000
Programming cable, Multi-USB adapter		05.C162RK1
SafeConfig parameterization software	download at	www.kuebler.com/safeconfig
Shield terminal for encoder cable, C profile rail		8.0000.4G06.0000
Connection technology		Order no.
Cordset, pre-assembled 2 m ¹⁾ for Sendix SIL encoders	cable, single-ended / 1 x Sub-D, 9-pin, male connector	8.0000.6V00.0002.0087
	cable, single-ended / 1 x Sub-D, 9-pin, female connector	8.0000.6V00.0002.0086
	cable with 1 x M23 / 1 x Sub-D, 9-pin, female connector	8.0000.6V00.0002.0085
	cable with 1 x M12 / 1 x Sub-D, 9-pin, female connector	8.0000.6V00.0002.0084

Further accessories can be found in accessories area of our website at: www.kuebler.com/accessories.

Additional connectors can be found in the connection technology section or in the connection technology area of our website at: www.kuebler.com/connection_technology.

You will find an overview of our systems and components for Functional Safety under www.kuebler.com/safety.

Technical data

General data	
Digital input lines	4 / 2
Digital output lines	8 / 4
Safe relay outputs	1
Type of connection	pluggable terminals
Max. terminal cross section	1.5 mm ² [AWG 15]
Drive monitoring - number of axis	1 axis

Electrical characteristics	
Power supply	24 V DC / 2.5 A
Tolerance	±20 %
Current consumption (no load)	max. 150 mA
Power consumption	max. 45 W
Fuse on power supply	max. 2.5 A, medium time-lag
Rated encoder power supply data	approx. 2V below the supply voltage / max. 200 mA

Environmental data	
Operating temperature	-20°C ... +55°C [-4°F ... +131°F]
Storage temperature	-25°C ... +70°C [-13°F ... +158°F]
Protection acc. to EN 60529	IP20
Climate class	3 acc. to DIN 50178 (non condensing)
CE compliant acc. to	EMC guideline 2014/30/EU Machinery directive 2006/42/EC Low voltage guideline 2014/35/EU RoHS guideline 2011/65/EU

Safety characteristics	
Classification	PLe / SIL3
System structure	2 channel (Cat. 3 / HFT = 1)
PFH _d value	3.76 x 10 ⁻⁸ h ⁻¹
Mission time / Proof test interval	20 years
Reaction times	see operating instructions R60719
Relevant standards	EN ISO 13849-1:2008 EN 62061:2005 EN 61508:2011

EMC	
Relevant standards	EN 61000-6-2:2005 / AC:2005 EN 61000-6-4:2007 / A1:2011 EN 61326-3-2:2008

Mechanical characteristics	
Size w x h x d	50 x 100 x 165 mm [1.97 x 3.94 x 6.50"]
Weight	390 g [13.76 oz]
Mounting	snap-on mounting on standard head rail
Material	housing plastic
Shock resistance acc. to EN 60068-2-27	300 m/s ² , 11 ms 170 m/s ² , 6 ms
Vibration resistance acc. to EN 60068-2-6	70 m/s ² , 10 ... 200 Hz

LED display		
ERROR (yellow)	steadily on	error
	flashing quickly	peripheral alarm
	flashing slowly	DIP 1 = OFF, factory setting DIP 3 = OFF, programming mode
ON (green)	steadily on	power on

1) Other lengths available

Safety modules

Safety-M compact Basic module	Speed monitoring – SMC2.2	1 axis / 2 encoder systems
SinCos interface (IN) X6, X7		
Type of connection	Sub-D, male connector, 9-pin	
Signal	SinCos	
Frequency	max. 500 kHz	
Signal level	1 V _{pp} (±20 %)	
Signal offset	2,5 V (±0,1 V)	
Signal termination	120 Ω	
Output voltage	2 V below the supply voltage	
Output current	max. 200 mA	
Incremental interface (IN) X8, X9		
Type of connection	pluggable screw terminals, 7-pin	
Signal	RS422 / TTL	
Frequency	max. 500 kHz	
Signal termination	120 Ω, 220 pF	
Digital inputs (IN) X10		
Type of connection	pluggable screw terminals, 5-pin	
HTL signal	incremental interface, Proximity switches or digital inputs	
Frequency	max. 250 kHz (incremental), max. 1 kHz (control signal)	
Signal level	PNP (24 V DC / 15 mA)	
Execution	complementary	
Relay outputs (OUT) X1		
Type of connection	pluggable screw terminals, 2-pin	
Wiring	two internally in line	
Type	positively driven (NO)	
Switching ability	5 ... 36 V DC	
Switching capacity	5 ... 5000 mA	
Digital switching outputs (OUT) X2		
Type of connection	pluggable screw terminals, 8-pin	
Signal	HTL / push-pull	
Rated data digital output	24 V DC / 30 mA	
Incremental interface / RS422 (OUT) X4		
Type of connection	pluggable screw terminals, 7-pin	
Signal	RS422 / TTL	
Frequency	max. 500 kHz	
Signal delay	SinCos ↔ RS422: 600 ns RS422 ↔ RS422: 600 ns HTL ↔ RS422: 600 ns	
Source	SinCos (X6, X7) incremental (X8, X9) HTL (X10)	
Analog interface (OUT) X4		
Type of connection	pluggable screw terminals, 7-pin	
Signal	analog	
Resolution	14 bit	
Accuracy	±0.1 %	
Output	1 ms	
Frequency	4 ... 20 mA	
Load	max. 270 Ω	
SinCos interface (OUT) X5		
Type of connection	Sub-D, female connector, 9-pin	
Signal	SinCos	
Signal level	1 V _{pp} (±20 %)	
Signal offset	2.5 V (±0.1 V)	
Frequency	max. 500 kHz	
Signal delay	SinCos ↔ SinCos 200 ns	
Source	SinCos (X6)	
USB interface X12		
Type	USB-B female connector	
Standard	USB 1.0	

Safety modules

Safety-M compact Basic module

Speed monitoring – SMC2.2

1 axis / 2 encoder systems

Terminal assignment

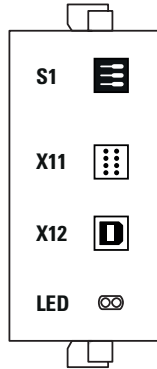
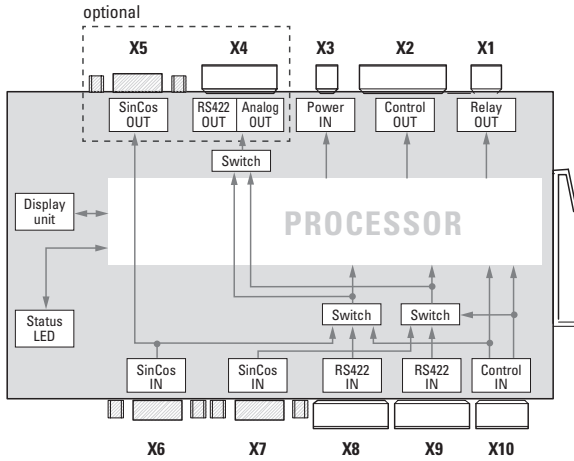

DIP switch S1



ON		Normal operation
OFF	1	Factory setting
	2	Self-test report
	3	Programming mode

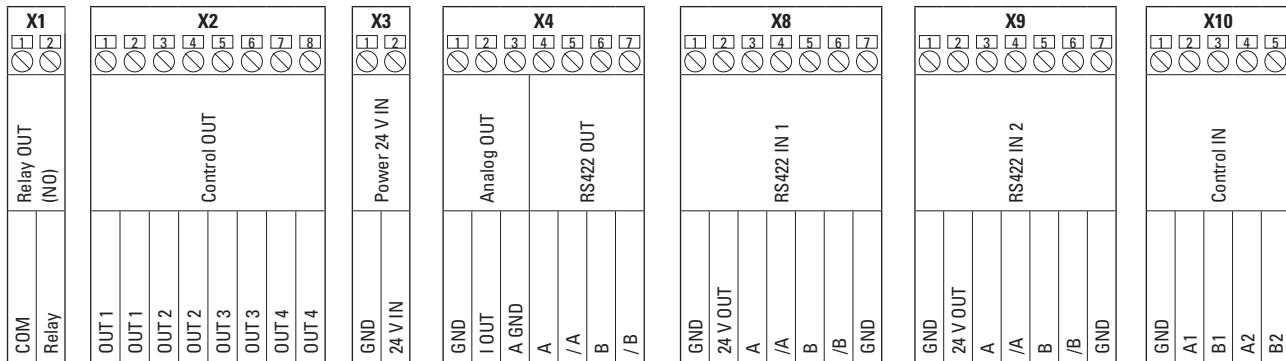

If the analog output is not used, terminals X4.2 and X4.3 must be bridged.

Interface	Sub-D female connector										
Terminal X5	Signal: SinCos	A	\bar{B}	B	-	0 V	-	-	-	\bar{A}	\perp
	Pin:	1	2	3	4	5	6	7	8	9	PH

Interface	Sub-D male connector										
Terminal X6, X7	Signal: SinCos	A	\bar{B}	B	+V	0 V	-	-	-	\bar{A}	\perp
	Pin:	1	2	3	4	5	6	7	8	9	PH

- +V: Power supply encoder +V DC
- 0 V: Encoder power supply ground GND (0V)
- A, \bar{A} : Cosine signal / Incremental channel A
- B, \bar{B} : Sine signal / Incremental channel B
- PH \perp : Plug connector housing (Shield)

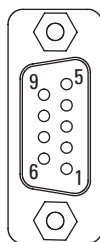

Sub-D female connector, 9-pin terminal X5

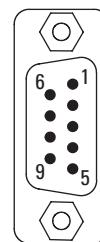

Sub-D male connector, 9-pin terminal X6, X7

Safety modules

Safety-M compact Basic module	Speed monitoring – SMC2.2	1 axis / 2 encoder systems
--	----------------------------------	-----------------------------------

Dimensions

Dimensions in mm [inch]

Basic module

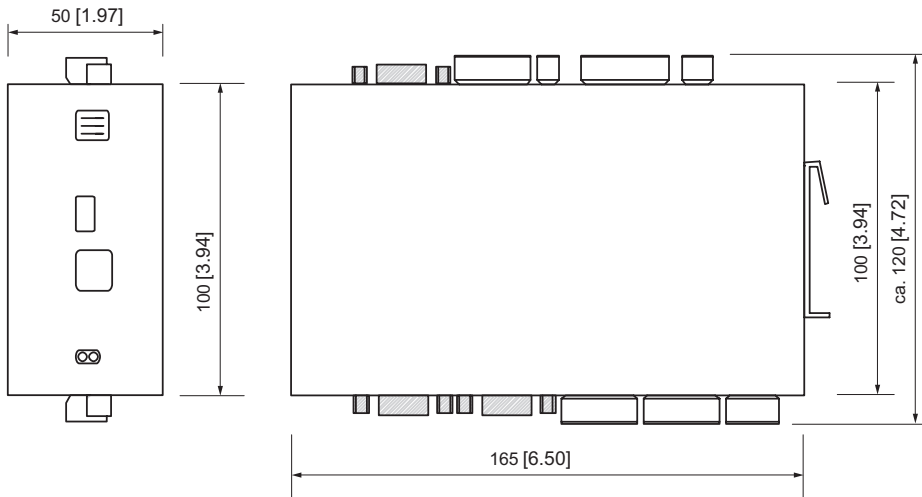

Control and diagnostic display – 8.SMCB.000

(further information can be found in the section accessories)

