

# Bearingless encoders

**Incremental, standard magnetic**

**RLI20 (hollow shaft)**

**Push-pull / RS422**



Thanks to its installation depth of only 16 mm, the bearingless magnetic rotary encoder RLI20, comprising a magnetic ring and sensor head, is ideally suited for plants and machinery where space is very tight. The non-contact measuring principle allows for error-free use even under harsh environmental conditions, as well as ensuring a long service life.

IP68 / IP69k protection, special encapsulation technology and tested resistance to cyclic humidity and damp heat offer the highest levels of reliability, even in exposed outdoor use.

This bearingless encoder can be mounted on shafts with a diameter up to max. 30 mm.



High rotational speed



High protection level



Shock / vibration resistant



Reverse polarity protection

## Hard-wearing and robust

- High shock and vibration resistance.
- Sturdy housing with IP67 protection. Option: special housing for maximum resistance against condensation (IP68 / IP69k, resistance to cyclic humidity acc. to EN 60068-3-38 as well as damp heat acc. to EN 60068-3-78).
- Non-contact measuring system, free from wear, ensures a long service life.

## Fast start-up

- Requires very little installation space.
- Large mounting tolerance between magnetic band and sensor head.
- Slotted hole fixing ensures simple alignment.
- Function display via LED.

## Order code

**RLI20**

**8.RLI20 . X1XX . XXXX . XXXX**

Type

a

b

c

d

e

### a Model

- 1 = IP67, standard
- 2 = IP68 / IP69k and humidity tested acc. to EN 60068-3-38, EN 60068-3-78

### b Output circuit / Power supply

- 1 = RS422 / 4.8 ... 26 V DC
- 2 = Push-pull / 4.8 ... 30 V DC

### c Type of connection

- 1 = radial cable, 2 m [6.56'] PUR
- A = radial cable, special length PUR \*)
- \*) Available special lengths (connection type A): 3, 5, 8, 10, 15 m [9.84, 16.40, 26.25, 32.80, 49.21']  
order code expansion .XXXX = length in dm  
ex.: 8.RLI20.111A.0250.0080.0030 (for cable length 3 m)

### d Pulses per revolution <sup>1)</sup>

0250, 0360, 1000, 1024, 2500, 3600

### e Bore diameter

0080 = 8 mm [0.32"]      0095 = 3/8"  
0100 = 10 mm [0.39"]      0158 = 5/8"  
0120 = 12 mm [0.47"]      0254 = 1" <sup>2)</sup>  
0150 = 15 mm [0.59"]  
0180 = 18 mm [0.71"]  
0200 = 20 mm [0.79"]  
0250 = 25 mm [0.98"] <sup>2)</sup>  
0300 = 30 mm [1.18"] <sup>2)</sup>

## Accessories / Display type 572

Order no.

### Position display, 6-digit

with 4 fast switch outputs and serial interface

**6.572.0116.D05**

with 4 fast switch outputs and serial interface and scalable analog output

**6.572.0116.D95**

### Position display, 8-digit

with 4 fast switch outputs and serial interface

**6.572.0118.D05**

with 4 fast switch outputs and serial interface and scalable analog output

**6.572.0118.D95**

Further accessories can be found in the accessories section or in the accessories area of our website at: [www.kuebler.com/accessories](http://www.kuebler.com/accessories).  
Additional connectors can be found in the connection technology section or in the connection technology area of our website at: [www.kuebler.com/connection\\_technology](http://www.kuebler.com/connection_technology).

1) Other pulse rates on request.  
2) Only possible for pulse rates 0360 and 3600.

# Bearingless encoders

<b>Incremental, standard magnetic</b>	<b>RLI20 (hollow shaft)</b>	<b>Push-pull / RS422</b>
---------------------------------------	-----------------------------	--------------------------

## Technical data

Mechanical characteristics	
<b>Maximum speed</b>	12000 min <sup>-1</sup>
<b>Protection</b>	Model 1 IP67 acc. to EN 60529 Model 2 IP68 / IP69k acc. to EN 60529, DIN 40050-9 and humidity tested acc. to EN 60068-3-38, EN 60068-3-78
<b>Working temperature</b>	-20°C ... +80°C [-4°F ... +176°F]
<b>Shock resistance</b>	5000 m/s <sup>2</sup> , 1 ms
<b>Vibration resistance</b>	300 m/s <sup>2</sup> , 10 ... 2000 Hz
<b>Pole gap</b>	2 mm from pole to pole
<b>Housing (sensor head)</b>	aluminum
<b>Cable</b>	2 m [6.56'] long, PUR 8 x 0.14 mm <sup>2</sup> [AWG 26], shielded, may be used in trailing cable installations
<b>Status LED</b>	green pulse-index red error; speed too high or magnetic fields too weak
<b>CE compliant acc. to</b>	EMC guideline 2014/30/EU RoHS guideline 2011/65/EU

### Signal figures

- 1 Pulse edge interval: Pay attention to the instructions in the technical data
- 2 Periodic index signal every 2 mm [0.08"]; the logical assignment A, B and 0-signal can change

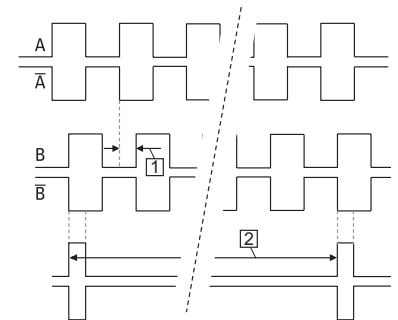

Electrical characteristics					
Output circuit	RS422	Push-pull			
<b>Power supply</b>	4.8 ... 26 VDC	4.8 ... 30 VDC			
<b>Power consumption (no load)</b>	typ. 25 mA max. 60 mA	typ. 25 mA max. 60 mA			
<b>Permissible load / channel</b>	120 Ohm	+/- 20 mA			
<b>Min. pulse edge interval</b>	1 µs	1 µs			
<b>Signal level</b>	HIGH min. 2.5 V LOW max. 0.5 V	min. +V - 2.0 V max. 0.5 V			
<b>Reference signal</b>	index periodical <sup>1)</sup>				
<b>System accuracy</b>	typ. 0.3° with shaft tolerance g6				
<b>Pulse rate [ppr] <sup>2)</sup></b>	<b>250, 360</b>	<b>1000</b>	<b>1024</b>	<b>2500</b>	<b>3600</b>
max. speed min <sup>-1</sup>	12000	2400	7000	3900	2700

### Terminal assignment

Output circuit	Type of connection	Cable (isolate unused cores individually before initial start-up)									
1, 2	1, A	Signal:	0 V	+V	A	$\bar{A}$	B	$\bar{B}$	0	$\bar{0}$	$\perp$
		Core color:	WH	BN	GN	YE	GY	PK	BU	RD	shield <sup>3)</sup>

- +V: Encoder power supply +V DC
- 0 V: Encoder power supply ground GND (0 V)
- A,  $\bar{A}$ : Incremental output channel A / cosine signal
- B,  $\bar{B}$ : Incremental output channel B / sine signal
- 0,  $\bar{0}$ : Reference signal
- $\perp$ : Plug connector housing (shield)

1) At every pole change. The signal is generated by the sensor.  
 2) With an input frequency of the evaluation unit of 250 kHz.  
 3) Shield is attached to connector housing.

# Bearingless encoders

**Incremental, standard magnetic**

**RLI20 (hollow shaft)**

**Push-pull / RS422**

## Mounting orientation and permissible mounting tolerances

### Distances

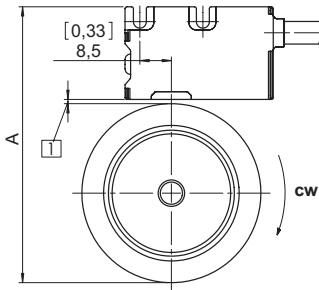

1 Distance sensor head / magnetic ring:  
0.1 ... 1.0 (0.4 [0.02] recommended)

Pulse rate	A for distance sensor head / magnetic ring: = 0.4 [0.02]
250, 1000, 2500	56.4 [2.22]
1024	66.6 [2.62]
360, 3600	70.4 [2.77]

### Torsion

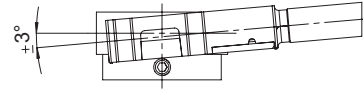

### Offset

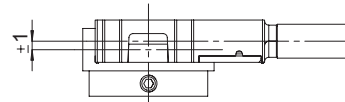

### Tilting

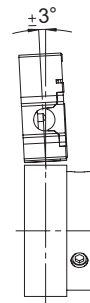

**Warning: When mounting the sensor head, please ensure its correct orientation to the magnetic ring!**

## Dimensions

Dimensions in mm [inch]

### Sensor head

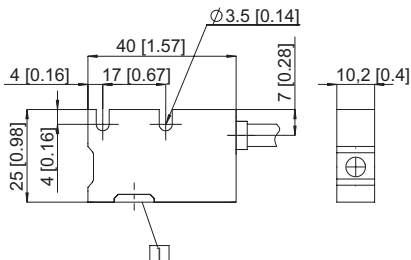

### Magnetic ring for pulse rate 250, 1000 or 2500

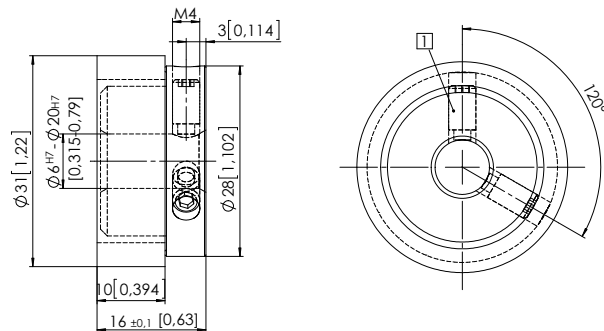

### Magnetic ring for pulse rate 1024

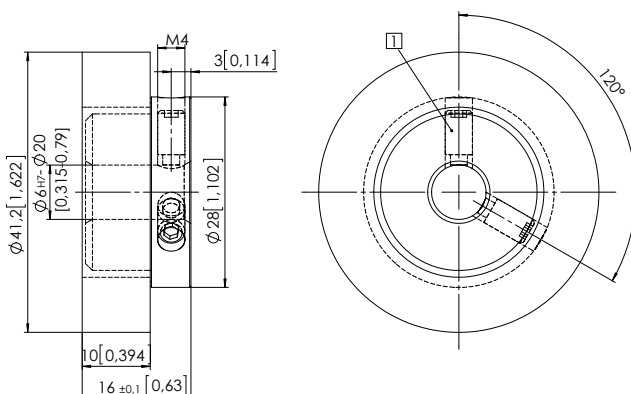

### Magnetic ring for pulse rate 360 or 3600

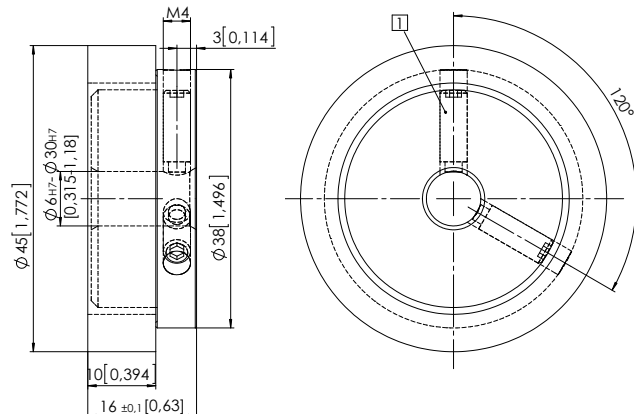

1 Set screw M4

Recommended tolerance of the drive shaft diameter: g6