

Absolute encoders – multiturn

Compact electronic multiturn, magnetic	Sendix M3668 / M3688 (shaft / hollow shaft)	SAE J1939
---	--	------------------



The Sendix M36 with Energy Harvesting Technology is an electronic multiturn encoder in a compact design, without gear and without battery.

It is characterized by robustness, reliability and cost-efficiency.

e1 pending c UL US Ex 2/22 RoHS **SAE J1939**

Safety-Lock™	High rotational speed	Temperature range -40°... +85°C	High protection level IP	High shaft load capacity	Shock / vibration resistant	Reverse polarity protection	Surface protection salt spray-tested optional	Energy Harvesting

Reliable and insensitive

- Sturdy bearing construction in Safety-Lock™ design for resistance against vibration and installation errors.
- Reduced number of components ensures magnetic insensitivity.
- IP67 protection and wide temperature range -40°C ... +85°C.
- Without gear and without battery, thanks to the Energy Harvesting technology.

Up-to-the-minute fieldbus performance

- Up-to-the-minute fieldbus performance in the application: SAE J1939 with CAN-highspeed to ISO 11898.
- Universal Scaling Function.
- Fast determination of the operating status via two-color LED.

Order code 8.M3668 . XX3X . 32 22
Shaft version Type a b c d e

If for each parameter of an encoder the underlined preferred option is selected, then the delivery time will be 10 working days for a maximum of 10 pieces. Qts. up to 50 pcs. of these types generally have a delivery time of 15 working days.



a Flange

- 1 = clamping flange, IP67, ø 36 mm [1.42"]
- 3 = clamping flange, IP65, ø 36 mm [1.42"]
- 2 = synchro flange, IP67, ø 36 mm [1.42"]
- 4 = synchro flange, IP65, ø 36 mm [1.42"]

b Shaft (ø x L), with flat

- 1 = ø 6 x 12.5 mm [0.24 x 0.49"]
- 3 = ø 8 x 15 mm [0.32 x 0.59"]
- 5 = ø 10 x 20 mm [0.39 x 0.79"]
- 2 = ø 1/4" x 12.5 mm [0.49"]

c Interface / power supply

- 3 = SAE J1939 / 10 ... 30 V DC

d Type of connection

- 1 = axial cable, 1 m [3.28'] PVC
- A = axial cable, special length PVC *)
- 2 = radial cable, 1 m [3.28'] PVC
- B = radial cable, special length PVC *)
- 3 = axial M12 connector, 5-pin
- 4 = radial M12 connector, 5-pin

*) Available special lengths (connection types A, B):
 2, 3, 5, 8, 10, 15 m [5.56, 9.84, 16.40, 26.25, 32.80, 49.21']
 order code expansion .XXXX = length in dm
 ex.: 8.M3668.433A.3222.0030 (for cable length 3 m)

e Fieldbus profile

- 32 = SAE J1939

Optional on request

- Ex 2/22 (only for connection types 3 and 4)
- surface protection salt spray tested

Absolute encoders – multiturn

Compact electronic multiturn, magnetic	Sendix M3668 / M3688 (shaft / hollow shaft)	SAE J1939
---	--	------------------

Order code Hollow shaft	8.M3688 Type	XX3X a b c d	32 2 2 e	If for each parameter of an encoder the <u>underlined preferred option</u> is selected, then the delivery time will be 10 working days for a maximum of 10 pieces. Qts. up to 50 pcs. of these types generally have a delivery time of 15 working days.	10 by 10
a Flange	2 = with stator coupling, IP65, ø 46 mm [1.81"] 3 = with spring element, long, IP65 5 = with stator coupling, IP67, ø 46 mm [1.81"] 6 = with spring element, long, IP67	c Interface / power supply	3 = SAE J1939 / 10 ... 30 V DC	e Fieldbus profile	32 = SAE J1939
b Blind hollow shaft (insertion depth max. 18.5 mm [0.73"])	1 = ø 6 mm [0.24"] 3 = ø 8 mm [0.32"] 4 = ø 10 mm [0.39"] 2 = ø 1/4"	d Type of connection	1 = axial cable, 1 m [3.28'] PVC A = axial cable, special length PVC *) 2 = radial cable, 1 m [3.28'] PVC B = radial cable, special length PVC *) 3 = axial M12 connector, 5-pin 4 = radial M12 connector, 5-pin	Optional on request	- Ex 2/22 (only for connection types 3 and 4) - surface protection salt spray tested
		*) Available special lengths (connection types A, B): 2, 3, 5, 8, 10, 15 m [5.56, 9.84, 16.40, 26.25, 32.80, 49.21'] order code expansion .XXXX = length in dm ex.: 8.M3688.243A.3222.0030 (for cable length 3 m)			

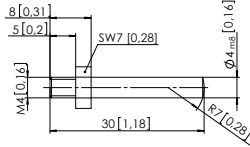
Mounting accessory for shaft encoders		Order no.
Coupling	Bellows coupling ø 19 mm [0.75"] for shaft 8 mm [0.32"]	8.0000.1102.0808
Mounting accessory for hollow shaft encoders		Order no.
Cylindrical pin, long for flange with spring element (flange type 3 + 6)	with fixing thread 	8.0010.4700.0000
Connection technology		Order no.
Cordset, pre-assembled	M12 female connector with coupling nut, 5-pin 5 m [16.40'] PVC cable	05.00.6091.A211.005M
Connector, self-assembly (straight)	M12 female connector with coupling nut, 5-pin	8.0000.5116.0000

Further accessories can be found in the accessories section or in the accessories area of our website at: www.kuebler.com/accessories.
Additional connectors can be found in the connection technology section or in the connection technology area of our website at: www.kuebler.com/connection_technology.

Technical data	
Mechanical characteristics	
Maximum speed	shaft or blind hollow shaft version 6000 min ⁻¹ without shaft seal (IP65) 3000 min ⁻¹ (continuous)
	shaft or blind hollow shaft version 4000 min ⁻¹ with shaft seal (IP67) 2000 min ⁻¹ (continuous)
Starting torque at 20°C [68°F]	without shaft seal < 0.007 Nm with shaft seal (IP67) < 0.01 Nm
Shaft load capacity	radial 40 N axial 20 N
Weight	approx. 0.2 kg [7.06 oz]
Protection acc. to EN 60529	IP65 or IP67
Working temperature range	-40°C ... +85°C [-40°F ... +185°F]
Materials	shaft / hollow shaft stainless steel flange aluminum housing zinc die-cast cable PVC
Electrical characteristics	
Shock resistance acc. to EN 60068-2-27	2500 m/s ² , 6 ms
Vibration resistance acc. to EN 60068-2-6	300 m/s ² , 10 ... 2000 Hz
Power supply	10 ... 30 V DC
Current consumption (no load)	max. 30 mA
Reverse polarity protection of the power supply	yes
Short-circuit proof outputs	yes ¹⁾
e1 compliant acc. to (pending)	EU guideline 2009/19/EC (acc. to EN 55025, ISO 11452 and ISO 7637)
UL approval	file no. E224618
CE compliant acc. to	EMC guideline 2014/30/EU RoHS guideline 2011/65/EU

1) Short circuit proof to 0 V or to output when power supply correctly applied.

Absolute encoders – multiturn

Compact electronic multiturn, magnetic	Sendix M3668 / M3688 (shaft / hollow shaft)	SAE J1939
---	--	------------------

Interface characteristics SAE J1939	
Resolution singleturn	1 ... 16.384 (14 bit), scalable default: 16.384 (14 bit)
Absolute accuracy ¹⁾	±1°
Repeat accuracy	±0.2°
Number of revolutions (multiturn)	max. 536.870.912 (29 bit) scalable only via the total resolution default: 262.144 (18 bit)
Total resolution	1 ... 8.796.093.022.208 (43 bit), scalable default: 4.294.967.296 (32 bit)
Interface	CAN high-speed acc. to ISO 11898, CAN specification 2.0 B
Protocol	SAE J1939

Power-ON time	< 1200 ms
Baud rate	250 kbit/s switchable by software to 500 kbit/s
Node address	software configurable
Termination	software configurable

General information concerning SAE J1939

The protocol J1939 originates from the international Society of Automotive Engineers (SAE) and operates on the physical layer with high speed CAN as per ISO11898. The application emphasis lies in the area of the power train and chassis of commercial vehicles. It serves to transfer diagnostic data (for example, motor speed, position, temperature) and control information. Type series M3658 and M3678 encoders support the total functionality of J1939.

This protocol is a multimaster system with decentralized network management that does not involve channel-based communication.

It supports up to 254 logic nodes and 30 physical control devices per segment. The information is described as parameters (signals) and combined on 4 memory pages (data pages) into parameter groups (PGs). Each parameter group can be identified via a unique number, the parameter group number (PGN). Independently of this, each signal is assigned a unique SPN (suspect parameter number).

The major part of the communication occurs cyclically and can be received by all control devices without the explicit request for data (Broadcast). Furthermore the parameter groups are optimized to a length of 8 data bytes. This enables very efficient utilization of the CAN protocol. If greater amounts of data need to be transferred, then transport protocols (TP) can be used: BAM (broadcast announce message) and CDMT (connection mode data transfer). With BAM TP the transfer of data occurs as a broadcast.

Encoder implementation SAE J1939

- PGNs that are adaptable to the customer's application.
- Resolution of address conflicts -> Address Claiming (ACL).
- Continuous checking whether control addresses have been assigned twice within a network.
- Change of control device addresses during run-time.
- Unique identification of a control device with the help of a name that is unique worldwide. This name serves to identify the functionality of a control device in the network.
- Predefined PGs for position, speed and alarm.
- 250 kbit/s, 29 bit identifier.
- Watchdog controlled device.

A two-color LED, located on the rear of the encoder, signals the operating and fault status of the J1939 protocol, as well as the status of the internal sensor diagnostics.

1) Over the whole temperature range.

Absolute encoders – multiturn

**Compact
electronic multiturn, magnetic**

Sendix M3668 / M3688 (shaft / hollow shaft)

SAE J1939

Terminal assignment

Interface	Type of connection	Cable (isolate unused cores individually before initial start-up)					
3	1, 2, A, B	Signal:	+V	0 V	CAN_GND	CAN_H	CAN_L
		Core color:	BN	WH	GY	GN	YE

Interface	Type of connection	M12 connector, 5-pin					
3	3, 4	Signal:	+V	0 V	CAN_GND	CAN_H	CAN_L
		Pin:	2	3	1	4	5

Top view of mating side, male contact base

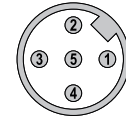

M12 connector, 5-pin

Dimensions shaft version

Dimensions in mm [inch]

Clamping flange, ø 36 [1.42] Flange type 1 and 3

1 3 x M3, 6 [0.24] deep

D	Fit	L
6 [0.24]	h7	12.5 [0.49]
8 [0.32]	h7	15 [0.59]
10 [0.39]	f7	20 [0.79]
1/4"	h7	12.5 [0.49]

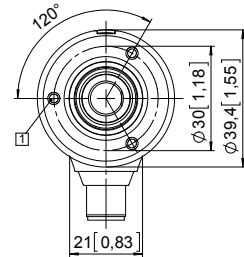
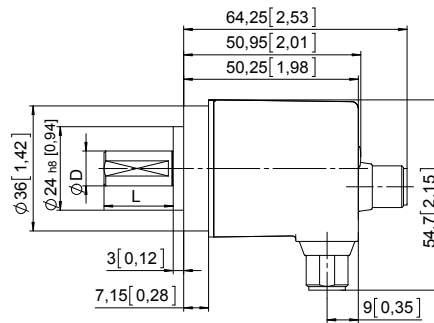

Synchro flange, ø 36 [1.42] Flange type 2 and 4

1 4 x M3, 6 [0.24] deep

D	Fit	L
6 [0.24]	h7	12.5 [0.49]
8 [0.32]	h7	15 [0.59]
10 [0.39]	f7	20 [0.79]
1/4"	h7	12.5 [0.49]

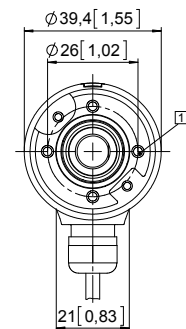
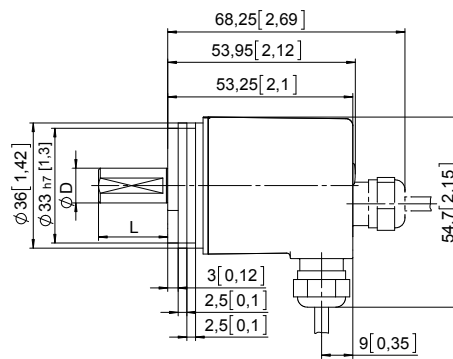

Absolute encoders – multiturn

Compact electronic multiturn, magnetic	Sendix M3668 / M3688 (shaft / hollow shaft)	SAE J1939
---	--	------------------

Dimensions hollow shaft version

Dimensions in mm [inch]

Flange with spring element, long Flange type 3 and 6

- 1 Slot spring element, recommendation: cylindrical pin DIN 7, $\varnothing 4$ [0.16]
- 2 Recommended torque for the clamping ring 0.7 Nm

D	Fit	L	D1
6 [0.24]	H7	18.5 [0.73]	24 [0.94]
8 [0.32]	H7	18.5 [0.73]	25.5 [1.00]
10 [0.39]	H7	18.5 [0.73]	25.5 [1.00]
1/4"	H7	18.5 [0.73]	24 [0.94]

L = insertion depth max. blind hollow shaft

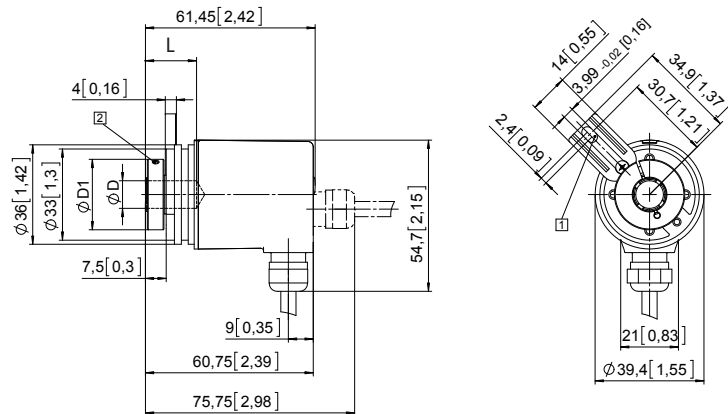

Flange with stator coupling, $\varnothing 46$ [1.81] Flange type 2 and 5

- 1 Recommended torque for the clamping ring 0.7 Nm

D	Fit	L	D1
6 [0.24]	H7	18.5 [0.73]	24 [0.94]
8 [0.32]	H7	18.5 [0.73]	25.5 [1.00]
10 [0.39]	H7	18.5 [0.73]	25.5 [1.00]
1/4"	H7	18.5 [0.73]	24 [0.94]

L = insertion depth max. blind hollow shaft

