



# SERIES PR90

## PROGRAMMABLE INCREMENTAL SOLID SHAFT ENCODER FOR INDUSTRIAL APPLICATIONS



Programmable incremental optical encoder from 1 to 65.536 pulses per rotation



Programmable via USB, without an additional programming box



Programmable without powering up the encoder



Multi-voltage 5...30V Automatic power voltage recognition



0° to 360° reference signal position



Optical Encoder



Incremental Encoder



Programmable Encoder



High shaft load capacity



Vibration and shock resistant



IP 65



Fast delivery

- External diameter 58 mm
- Shaft  $\varnothing$  6 or 10 mm
- Protection class IP65 according to DIN EN 60529
- Connection by cable (any cable length available) or industrial connector M12 or M23

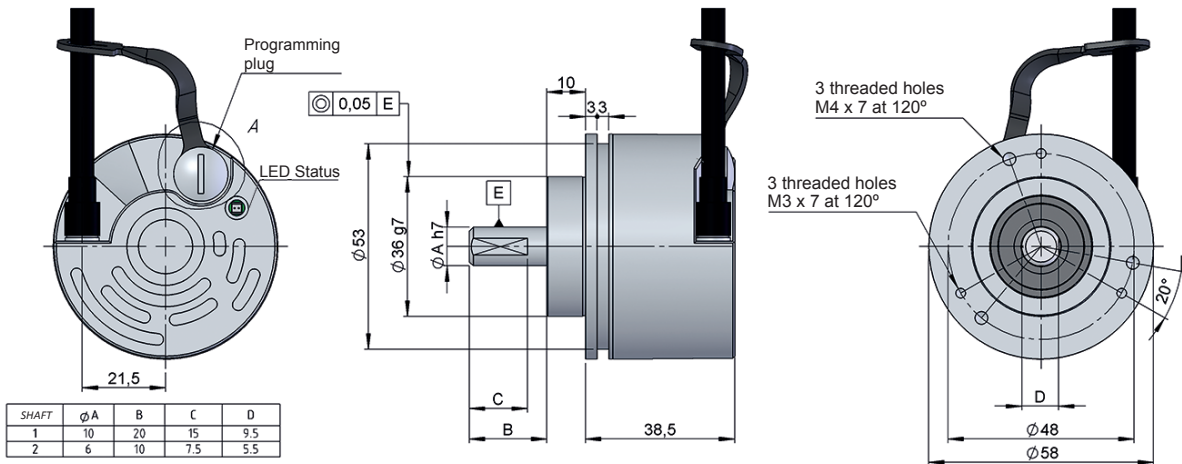
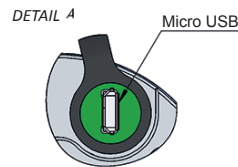

Drawing shaft type 1, connection type 1, without flange

### REFERENCE

Reference example: PR90-11C1C-C

Serie	Shaft	Flange	Output signals	Connection	Power Supply / Electronic output	Pulses number	Special customer
PR90 -	<input type="checkbox"/>	<input type="checkbox"/>	<input type="checkbox"/>	<input type="checkbox"/>	<input type="checkbox"/> -	<input type="checkbox"/>	<input type="checkbox"/> <input type="checkbox"/> <input type="checkbox"/> <input type="checkbox"/>
	1. $\varnothing$ 10x20mm 2. $\varnothing$ 6x10mm	1. None 3. 90.1102 5. 90.1005 (*)	C. A $\tilde{A}$ +B $\tilde{B}$ +0 $\tilde{0}$  CONFIGURABLE • CW / CCW • Z 90° and 180° • Z position of 0...360°	1. Helicoidal cable 2. Radial 90.9508 M12 8p CCW 3. Radial 90.9512 M23 12p CCW	C. 5...30 VDC / HTL - TTL  CONFIGURABLE • Electronic output HTL / TTL	C. 1...65536  CONFIGURABLE	

Female connector is not included in the reference. All options available in the sections "CONNECTION DIMENSIONS", upon request.

(\*) Flange mounting included in delivery of the encoder.

# SERIES PR90

## PROGRAMMABLE INCREMENTAL SOLID SHAFT ENCODER FOR INDUSTRIAL APPLICATIONS

### MECHANICAL SPECIFICATIONS

Materials	Cover: Aluminium Housing: Aluminium Shaft: Stainless Steel
Bearings	Ballraces
Bearings lifetime	1x10 <sup>10</sup> rev.
Maximum number of revolutions permitted mechanically	6000 rpm
Protection against dust and splashes according to DIN EN 60529	IP65
Rotor inertia moment	30 gcm <sup>2</sup>
Starting torque at 20°C (68°F)	≤ 0,01 Nm
Maximum load permitted on axial shaft	40 N
Maximum load permitted on radial shaft	80 N
Weight aprox.	0,5 Kg
Operating temperature range	-20°C a +80°C
Vibration according to DIN EN 60068-2-6	100 m/s <sup>2</sup> (10Hz...2000Hz)
Shock according to DIN EN 60068-2-27	1000 m/s <sup>2</sup> (6ms)
Maximum pulses per turn	65.536
Connection	2 meters cable or industrial connector M12 or M23 (other cable lengths available on order) <b>Female connector not included</b>

### OUTPUT SIGNALS

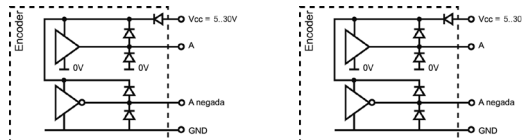

OUTPUT CIRCUIT	TTL	HTL
Reference code	C	C
Power supply	5...30 VDC	5...30 VDC
Consumption	Typical: 45 mA Max: 150 mA	Typical: 45 mA Max: 150 mA
Max. load capability / channel	±20 mA	±20 mA
Length of cable allowed	1200 m	1200 m
“Low” signal level	VOL < 0,5 VDC	VOL < 2.5 VDC
“High” signal level	VOH > 2.5 VDC	VOH > VCC – 1.5 VDC
Frequency	900 kHz	900 kHz
Short circuit protection	Yes	Yes
Protection polarity inversion	Yes	Yes

Configurable CW - Channel A leads (90° electric) channel B, view from the shaft, shaft rotating clockwise  
 Configurable CCW - Channel B leads (90° electric) channel A, view from the shaft, shaft rotating clockwise

# SERIES PR90

## PROGRAMMABLE INCREMENTAL SOLID SHAFT ENCODER FOR INDUSTRIAL APPLICATIONS

### CONNECTION



	95.0008011 Cable 4x2x0,14	90.9508 M12 8p CCW	90.9512 M23 12p CCW
GND	Black	7	10
VCC	Red	8	12
A	Yellow	2	5
B	Green	4	8
$\tilde{A}$	Brown	1	6
$\tilde{B}$	Blue	3	1
0 (reference)	Grey	6	3
$\tilde{0}$	Orange	5	4

Shield connected to the housing

### CONNECTION PC\*



90.9452  
Cable uUSB/USB

(\* ) The connection cable uUSB / USB is not included in the reference.

Available in the section "ACCESSORIES".

### PROGRAMMING DETAILS

#### LED Status:

● *green intermittent indicator:*  
Communication between devices

● *red indicator:*  
Error detection (overload, low power, optical failure, communications failure, humidity...)  
See type of error in the programming software

#### Configuration options:

Input Power Supply 5V to 30V

PPR: 4096

Output Voltage Control:  TTL  HTL

Direction:  Clockwise  Counter Clockwise

Z Pulse: Position:  Width:  180°  90°

Output:  A inverted  B inverted  Z inverted

#### Factory configuration:

- Pulses: 4096 ppr
- Output: HTL
- Direction: Clockwise (CW)
- Position (Z pulse): 0°
- Width (Index, Z, 0): 90°

### FLANGE DIMENSIONS

Flange mounting included

Flange 2  
90.1102

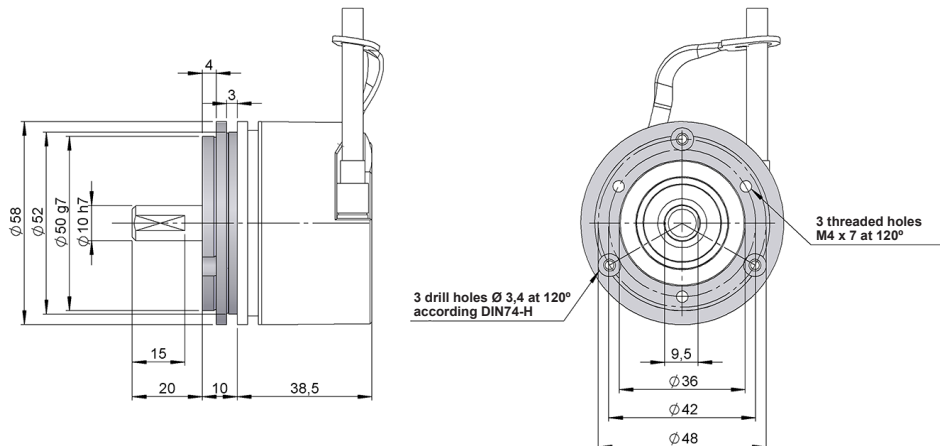

# SERIES PR90

## PROGRAMMABLE INCREMENTAL SOLID SHAFT ENCODER FOR INDUSTRIAL APPLICATIONS

Flange 3  
90.1005

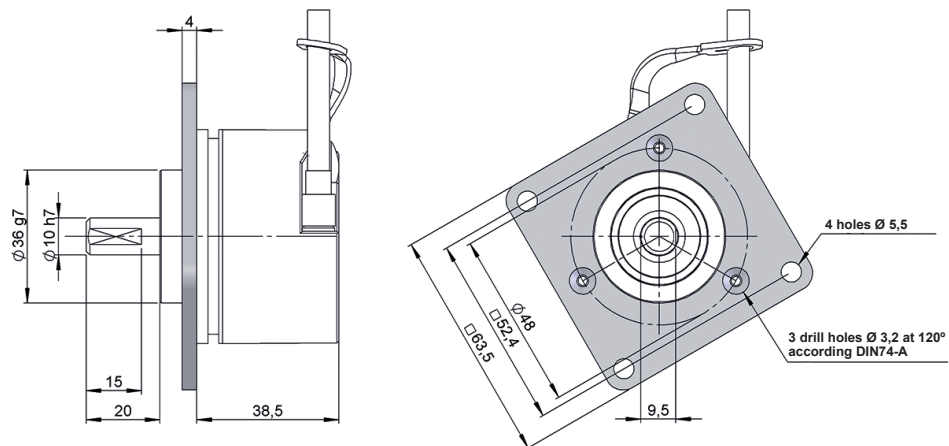

### CONNECTION DIMENSIONS

Female connector not included

Connection 2  
Radial 90.9508

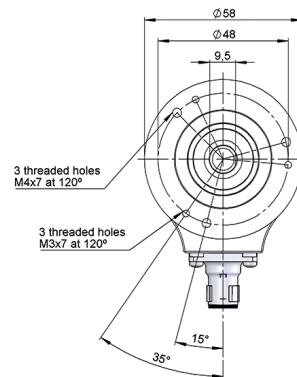
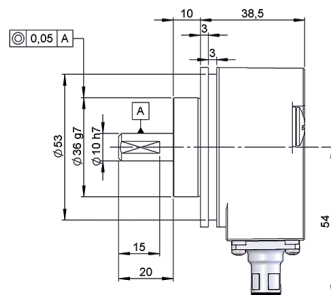
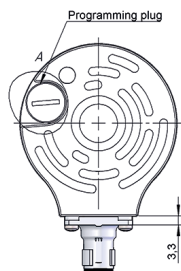
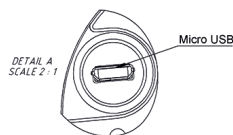

90.9508

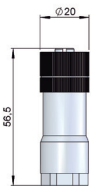

90.9508

M12 8p  
male connector  
counter clockwise

Connection 3  
Radial 90.9512

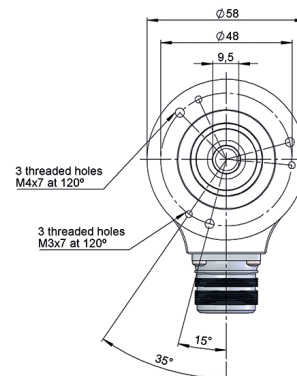
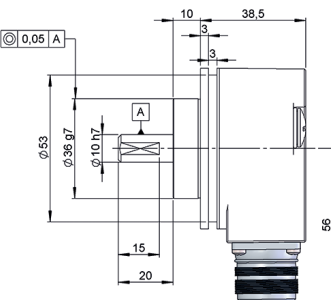
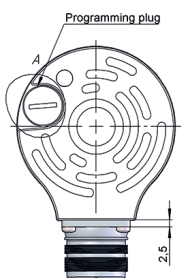
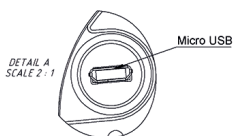

90.9512

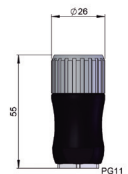

90.9512

M23 12p  
male connector  
counter clockwise