

Serie PEH Series PEH

Inkrementaler Drehgeber mit Hohlwelle, Motor Feedback *Incremental rotary encoder with hollow shaft, Motor feedback*

Mechanische Daten / Mechanics Data

Haube / Cover:	ABS
Flansch / Body:	Aluminium / Aluminium
Welle / Shaft:	Edelstahl / Stainless steel
Kugellager / Bearings:	doppelt gelagert / 2 ballraces
Gewicht / Weight:	150 g
IP Schutzart / IP Protection:	IP44
Umdrehungen / Rpm:	max. 6000
Drehmoment / Torque:	^3Ncm
Trägheitsmoment / Inertia:	40gcm ²
Wellenbelastung / Shaft Loading:	Axi 30N - Rad 30N (max Wert / max value)

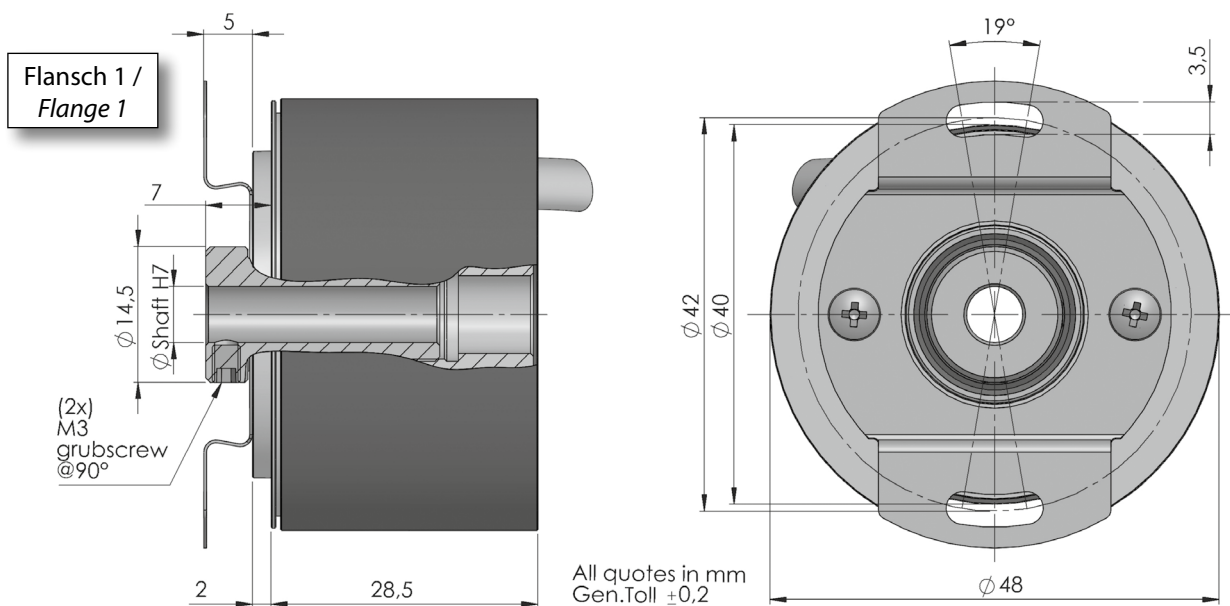
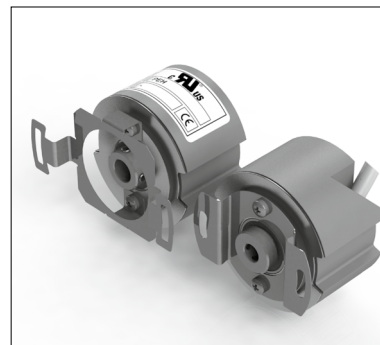

Flansch 2 /
Flange 2

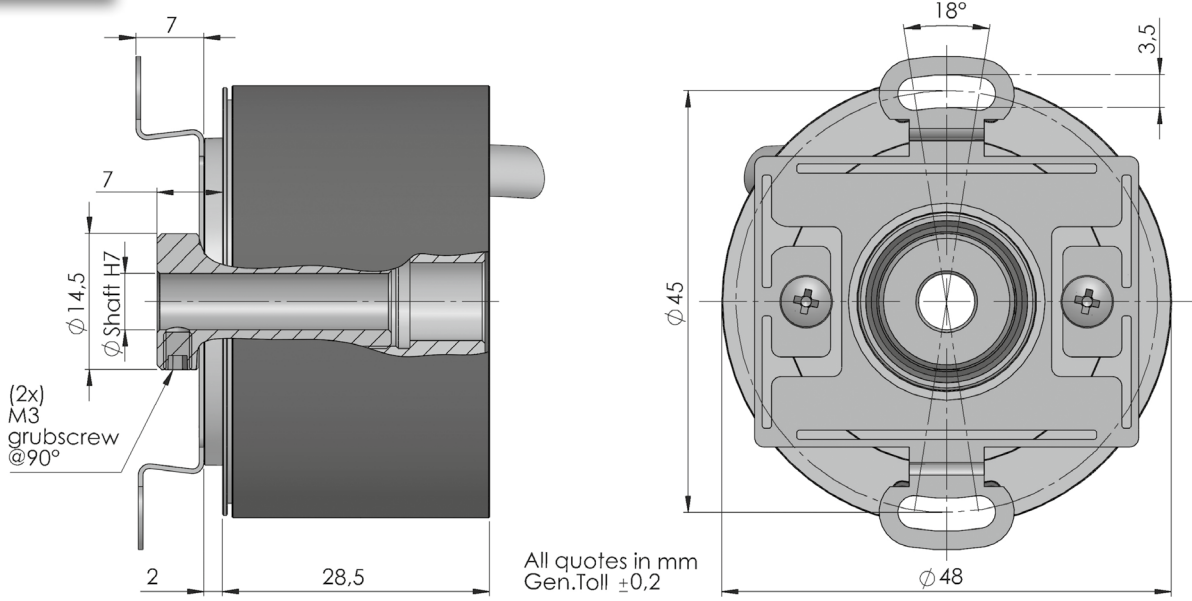

Flansch 3 /
Flange 3

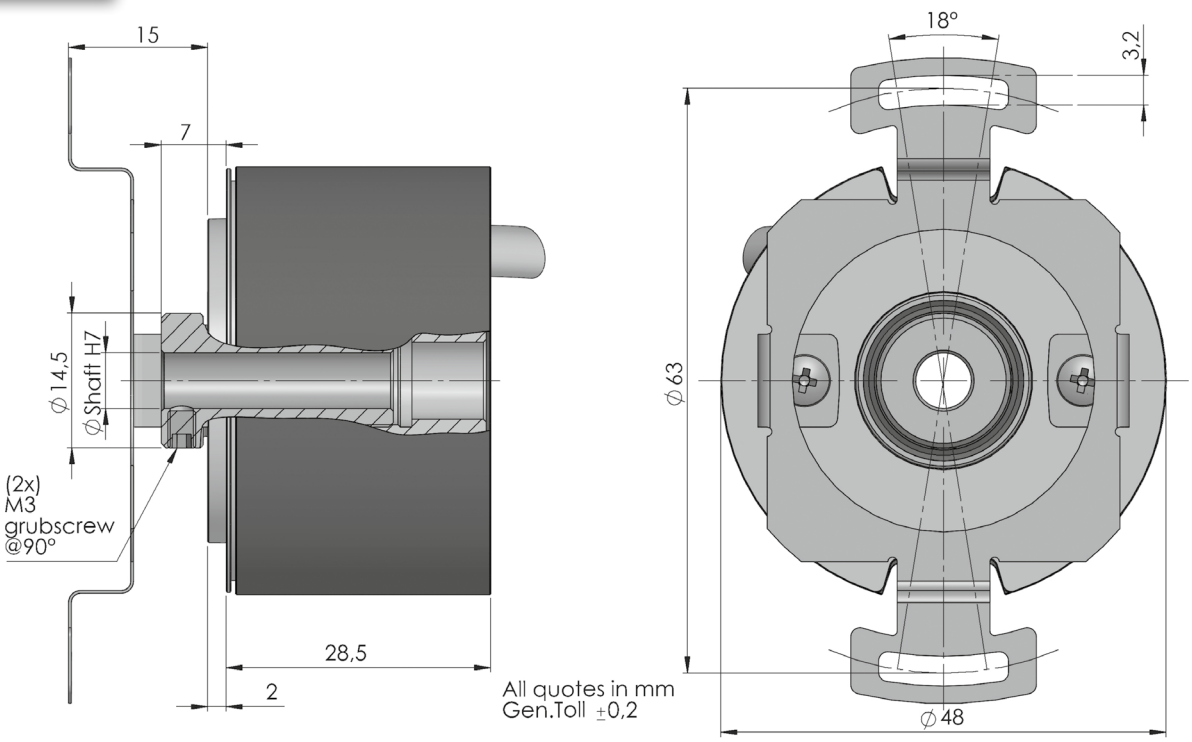

Ausgangssignale (cw) / Output Signals

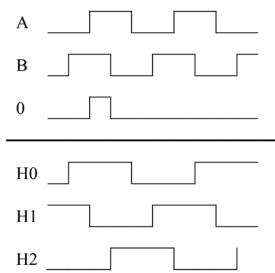

Elektronische Daten / Electronics Data

Versorgungsspannung / Power Supply:	5/28 Volt, hängt von der Ausgangsschaltung ab / depends on the electronics circuit
max. Stromaufnahme / Current consumption:	80mA (160mA with motor feedback)
Ausgangsbelastung / Load:	20/40mA, hängt von der Ausgangsschaltung ab / depends on the electronics circuit
Frequenz / Frequency:	Bis zu / Up to 300KHz
Schutz / Protections:	Kurzschlussfest, Umkehrpolarität / Against short circuit, reversal polarity
Betriebstemperatur / Operating Temp:	-10/+70°C (-30/+100°C auf Anfrage / on request)

Bestellbezeichnung / Ordering Code

PEH	*	*	*	*	**	/	****
	Welle Shaft	Flansche Flanges	Ausgangsschaltungen Output		Anschlüsse Connections	Optionen Options	Auflösung Resolution
	6 = Ø 6mm 8 = Ø 8mm	1 = 2 = 3 = Siehe vorherige Seiten See Previous pages	2 = AB	PP11/28V	Kabel / Cable 3 = Cavo Rad	0 = No motor feedback 4 = 4 poles 6 = 6 poles 8 = 8 poles U = Versorgungssp. 5/28V für PP Power supply 5/28V for outputs PP*	max. 2.048
			3 = AB0	PP11/28V			
			N = AB+AB	PP11/28V			
			P = AB0+AB0	PP11/28V			
			6 = AB0+AB0	LD5V			

* Option U: Ausgangspegel TTL kompatibel / outputs levels compatible TTL • Low level output <0.5V • High level output > +VCC-1,9V

Anschlüsse / Connections

-	Schwarz	Black
+	Blau	Blue
A	Braun	Brown
B	Beige	Beige
A-	Grün	Green
B-	Gelb	Yellow
0	Rosa	Pink
0-	Violett	Violett
H0	Orange	Orange
H1	Transparent	Transparent
H2	Gelb / Grün	Yellow / Green
H0-	Rot / Weiß	Red / White
H1-	Blau / Weiß	Blue / White
H2-	Gelb / Weiß	Yellow / White

Alle Bilder sind Beispielbilder und können nicht als verbindlich eingestuft werden
All images are indicative and can not be considered binding the purpose of supplying