

## Actuator 122MBV

The magnetic actuator was designed especially for use in the process area of food and packaging machines.

### Technical specifications

- Flexibility in installation and use from variable actuation direction
- Space saving and simple installation through small size
- Screw covers prevent easy removal and the accumulation of dirt
- Strong resistance against cleaning agents (ECOLAB) makes this suitable for use in the food and packaging industries.

### Technical drawing

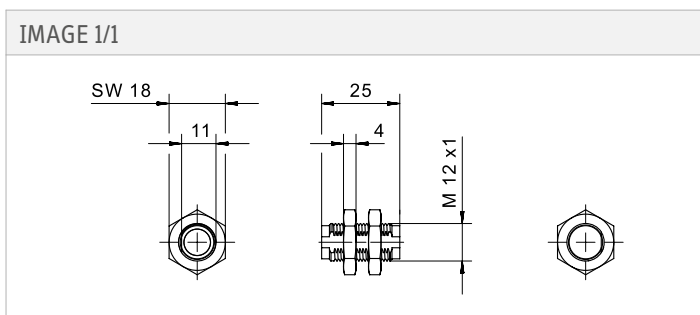

## Properties

Attribute	122MBV100
Coding acc. to EN ISO 14119	Low
Suitable for sensor type(s)	122MSV

## Mechanical data

Attribute	122MBV100
Dimensions	M12x44

## Material information

Attribute	122MBV100
Housing material	1.4404
Housing colour	silber
Nut material	1.4404

## Installation

Attribute	122MBV100
Mounting type	Fastening nut
Thread	M12