



# Online Data Sheet

## Encoder WDGA 58E CANopen galv. isolation

[www.wachendorff-automation.com/wdga58ecangalv](http://www.wachendorff-automation.com/wdga58ecangalv)

### Wachendorff Automation

#### ... systems and encoders

- Complete systems
- Industrial rugged encoders to suit your application
- Standard range and customer versions
- Maximum permissible loads
- 48-hour express production
- Made in Germany
- Worldwide distributor network

# Encoder WDGA 58E absolute CANopen, galv. isolation, magnetic, with EnDra®- Technology



**EnDra®**  
Technologie

**CANopen®**

- EnDra®: maintenance-free and environmentally friendly
- CANopen, Single-turn/Multi-turn
- Galvanic isolation
- Communication Profile according to CiA 301
- Device Profile for encoder CiA 406 V3.2 class C2
- Single-turn/Multi-turn (16 bit/43 bit)
- Forward-looking technology with 32 Bit processor
- 2-colour-LED as indicator for operating condition and error message appropriate CiA 303-3

[www.wachendorff-automation.com/wdga58ecangalv](http://www.wachendorff-automation.com/wdga58ecangalv)

Mechanical Data	
<b>Housing</b>	
Flange	hollow shaft (blind-bored)
Flange material	aluminum
Housing cap	steel case chrome-plated, magnetic shielding
Torque supports	incl. 1 torque support WDGDS10019
- 1. Spring plate compensation	axial: ±1.2 mm, radial: ±0.2 mm
- Max. operating speed	6000 rpm up to max. protection rating +80 °C
Housing	Ø 58 mm
<b>Shaft(s)</b>	
Shaft material	stainless steel
Starting torque	approx. 1.6 Ncm at ambient temperature, approx. 2.226 in-ozf at ambient temperature
Fixing	permanently attached clamping ring
Shaft	Ø 6 mm
Advice	with adapter sleeve
Shaft length	L: 17 mm
Insertion depth min.	10 mm
Insertion depth max.	19 mm
Max. Permissible shaft loading radial	80 N
Max. Permissible shaft loading axial	50 N
Shaft	Ø 6.35 mm, Ø 1/4"
Advice	with adapter sleeve
Shaft length	L: 17 mm, L: 0.669 in
Insertion depth min.	10 mm, 0.394 in
Insertion depth max.	19 mm, 0.748 in
Max. Permissible shaft loading radial	80 N, 8.158 kp
Max. Permissible shaft loading axial	50 N, 5.099 kp
Shaft	Ø 7 mm
Advice	with adapter sleeve
Shaft length	L: 17 mm
Insertion depth min.	10 mm
Insertion depth max.	19 mm
Max. Permissible shaft loading radial	80 N
Max. Permissible shaft loading axial	50 N

Shaft	Ø 8 mm
Advice	with adapter sleeve
Shaft length	L: 17 mm
Insertion depth min.	10 mm
Insertion depth max.	19 mm
Max. Permissible shaft loading radial	80 N
Max. Permissible shaft loading axial	50 N
Shaft	Ø 9.525 mm, Ø 3/8"
Advice	with adapter sleeve
Shaft length	L: 17 mm, L: 0.669 in
Insertion depth min.	10 mm, 0.394 in
Insertion depth max.	19 mm, 0.748 in
Max. Permissible shaft loading radial	80 N, 8.158 kp
Max. Permissible shaft loading axial	50 N, 5.099 kp
Shaft	Ø 10 mm
Advice	with adapter sleeve
Shaft length	L: 17 mm
Insertion depth min.	10 mm
Insertion depth max.	19 mm
Max. Permissible shaft loading radial	80 N
Max. Permissible shaft loading axial	50 N
Shaft	Ø 12 mm
Shaft length	L: 17 mm
Insertion depth min.	10 mm
Insertion depth max.	19 mm
Max. Permissible shaft loading radial	80 N
Max. Permissible shaft loading axial	50 N
Shaft	Ø 14 mm
Shaft length	L: 17 mm
Insertion depth min.	10 mm
Insertion depth max.	19 mm
Max. Permissible shaft loading radial	80 N
Max. Permissible shaft loading axial	50 N

Bearings	
Bearings type	2 precision ball bearings
Nominal service life	1 x 10 <sup>9</sup> revs. at 100 % rated shaft load 1 x 10 <sup>10</sup> revs. at 40 % rated shaft load 1 x 10 <sup>11</sup> revs. at 20 % rated shaft load
Max. operating speed	6000 rpm

Electrical Data	
Power supply/Current consumption	10 VDC up to 32 VDC: typ. 100 mA
Power consumption	max. 1 W

Sensor data	
Single-turn technology	innovative hall sensor technology
Single-turn resolution	65,536 steps/360° (16 bit)
Single-turn accuracy	< ±0.35°
Single-turn repeat accuracy	< ±0.20°
Internal cycle time	600 µs
Multi-turn technology	patented EnDra® technology no battery and no gear.
Multi-turn resolution	up to 32 bit with high precision value up to 43 bit.

Environmental data	
<b>Environmental data:</b>	
ESD (DIN EN 61000-4-2):	8 kV
Burst (DIN EN 61000-4-4):	2 kV
includes EMC:	DIN EN 61000-6-2 DIN EN 61000-6-3
Vibration: (DIN EN 60068-2-6)	50 m/s <sup>2</sup> (10 Hz up to 2000 Hz)
Shock: (DIN EN 60068-2-27)	1000 m/s <sup>2</sup> (6 ms)
Design:	according DIN VDE 0160
Turn on time:	<1,5 s

Interface	
<b>Interface:</b>	<b>CAN</b>
Protocol:	CANopen <ul style="list-style-type: none"> <li>• Communication profile CiA 301</li> <li>• Device Profile for encoder CiA 406 V3.2 class C2</li> </ul>
Node number:	1 up to 127 (default 127)
Baud rate:	50 kBaud up to 1 MBaud with automatic bit rate detection.
Advice:	The standard settings as well as any customization in the software can be changed via LSS (CiA 305) and the SDO protocol, e. g. PDOs, Scaling, Heartbeat, Node-ID, Baud rate, etc.
Programmable CAN transmission modes:	<b>Synchronous mode:</b> when a synchronisation telegram (SYNC) is received from another bus node, PDOs are transmitted independently. <b>Asynchronous mode:</b> a PDO message is triggered by an internal event. (e.g. change of measured value, internal timer, etc.)

General Data	
Weight	approx. 410 g
Connections	connector outlet
Protection rating (EN 60529)	Housing: IP65, IP67; shaft sealed: IP65
Operating temperature	-40 °C up to +85 °C, -40 °F up to +176 °F
Storage temperature	-40 °C up to +100 °C, -40 °F up to +212 °F

More Information	
General technical data and safety instructions <a href="http://www.wachendorff-automation.com/gtd">http://www.wachendorff-automation.com/gtd</a>	
Options <a href="http://www.wachendorff-automation.com/acc">http://www.wachendorff-automation.com/acc</a>	

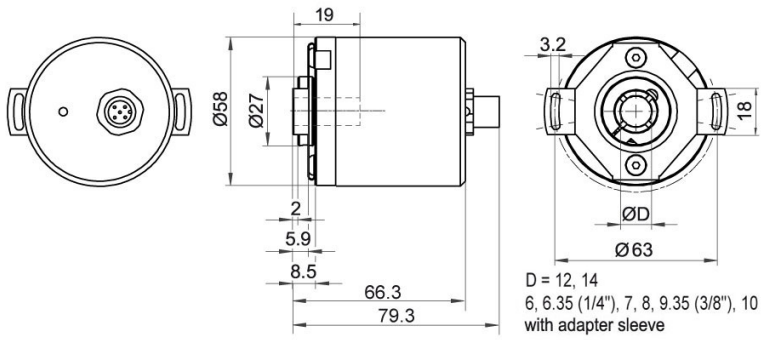
**WDGA 58E CANopen galv. isolation with M12x1, axial CB5, 5-pin**

**Description**

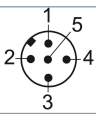
**CB5** axial, 5-pin, shield connected to encoder housing

Assignments	
	<b>CB5</b> 
<b>(+) Vcc</b>	2
<b>GND</b>	3
<b>CANHigh</b>	4
<b>CANLow</b>	5
<b>CANGND shield</b>	1

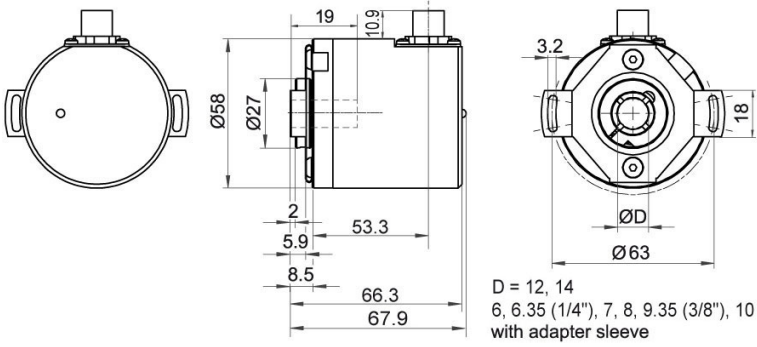
**WDGA 58E CANopen galv. isolation with M12x1, radial CC5, 5-pin**



**Description**

**CC5** radial, 5-pin, shield connected to encoder housing

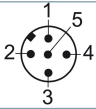
Assignments	
	<p><b>CC5</b></p> 
<b>(+) Vcc</b>	2
<b>GND</b>	3
<b>CANHigh</b>	4
<b>CANLow</b>	5
<b>CANGND shield</b>	1

**WDGA 58E CANopen galv. isolation with 2x M12x1, axial DB5, 5-pin**

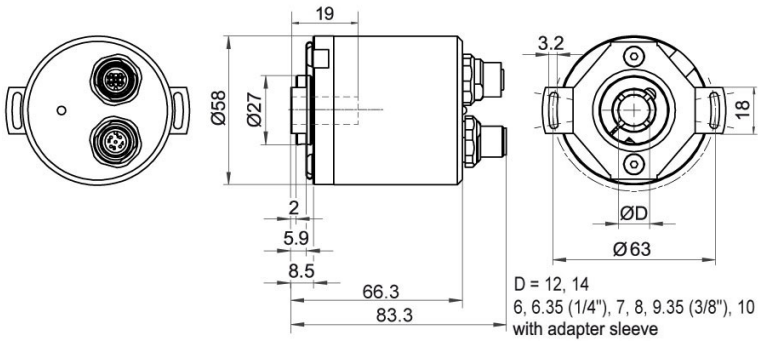

**Description**

**DB5** axial, 5-pin, shield connected to encoder housing

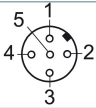
Assignments	
	
<b>Female connector</b>	M12x1, 5-pin
<b>(+) Vcc</b>	2
<b>GND</b>	3
<b>CANHigh</b>	4
<b>CANLow</b>	5
<b>CANGND shield</b>	1

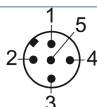
Assignments	
	
<b>Connector</b>	M12x1, 5-pin
<b>(+) Vcc</b>	2
<b>GND</b>	3
<b>CANHigh</b>	4
<b>CANLow</b>	5
<b>CANGND shield</b>	1

**Options****120 Ohm terminating resistor****Order key**

The encoder WDGA 58E CANopen galv. is also available with fixed 120 Ohm terminating resistor. **AEO**

---

Example Order No.	Type	Your encoder
WDGA 58E	WDGA 58E	WDGA 58E
	<b>Shaft</b>	<b>Order key</b>
12	Ø 6 mm with adapter sleeve	06
	Ø 6.35 mm Ø 1/4" with adapter sleeve	2Z
	Ø 7 mm with adapter sleeve	07
	Ø 8 mm with adapter sleeve	08
	Ø 9.525 mm Ø 3/8" with adapter sleeve	4Z
	Ø 10 mm with adapter sleeve	10
	Ø 12 mm	12
	Ø 14 mm	14
	<b>Single-turn Resolution</b>	<b>Order key</b>
12	Single-turn resolution 1 bit up to 16 bit: (e. G. 12 bit)	12
	<b>Multi-turn Resolution</b>	<b>Order key</b>
18	Multi-turn resolution: (examples) 18 bit = 18 43 bit = 43 no Multiturn = 00	18
	<b>Data protocol</b>	<b>Order key</b>
CO	CANopen (galv. isolation)	CO
	<b>Software</b>	<b>Order key</b>
A	up to date release	A
	<b>Code</b>	<b>Order key</b>
B	binary	B
	<b>Power supply</b>	<b>Order key</b>
0	10 V up to 32 V (standard)	0
	<b>Galvanic isolation</b>	<b>Order key</b>
1	yes	1
	<b>Electrical connections</b>	<b>Order key</b>
CB5	<b>Connector:</b>	
	sensor-connector, M12x1, 5-pin, axial, IP67, shield connected to encoder housing	CB5
	sensor-connector, M12x1, 5-pin, radial, IP67, shield connected to encoder housing	CC5
	sensor-connector/female connector, 2x M12x1, 5-pin, axial, IP67, shield connected to encoder housing	DB5
	<b>Options</b>	<b>Order key</b>
	Without option	Empty
	120 Ohm terminating resistor	AEO

<b>Example Order No.</b>	WDGA 58E	12	12	18	CO	A	B	0	1	CB5	
--------------------------	----------	----	----	----	----	---	---	---	---	-----	--

WDGA 58E											<b>Example Order No.</b>
----------	--	--	--	--	--	--	--	--	--	--	--------------------------





For further information please contact our local distributor.  
Here you find a list of our distributors worldwide.  
<https://www.wachendorff-automation.com/>



Wachendorff Automation GmbH & Co. KG  
Industriestrasse 7 • 65366 Geisenheim  
Germany

Phone: +49 67 22 / 99 65 25  
Fax: +49 67 22 / 99 65 70  
E-Mail: [wdg@wachendorff.de](mailto:wdg@wachendorff.de)  
[www.wachendorff-automation.de](http://www.wachendorff-automation.de)

